



FACTVM
FOVNDATION
FOR DIGITAL TECHNOLOGY
IN CONSERVATION

FACTVM FOVNDATION 2016

2016





FACTVM
FOVNDATION
FOR DIGITAL TECHNOLOGY
IN CONSERVATION

**Tradition is not the worship of ashes
but the preservation of fire**

Attributed to both
Thomas More and Gustav Mahler

2016
www.factumfoundation.org



A burnt crucifix, damaged in a fire at the Church of El Pilar, Mejorada del Campo. This extraordinary structure has been built by Justo Gallego over the past 55 years without money or support. Following the fire that damaged the crucifix it was agreed that Factum Foundation would scan and re-make this C19th sculpture over twice its original size (see page 58).



A facsimile of C12th Crucifix from the Auvergne (Musée de Cluny) made for Rachid Koraïchi. The original figure was loaned by the Musée Cluny for the exhibition *Dieu(x), Modes d'emploi* at the Grand Palais in 2012. Koraïchi's installation brought together works from each of the three Abrahamic religions in a spirit of understanding, respect and communication. The facsimile was made so that the exhibition could tour, taking the experience to many more people (see page 57).

The gift of the facsimile is a metaphor for the relationship between Europe and Egypt - the skills and technology that have been developed in Europe to create the facsimile are going to be transferred to Egypt where the local workers will be trained and those very skills and technology will become Egyptian.

Baroness Ashton, EU High Representative.
Extracted from a speech given at the EU task force in Cairo,
when the facsimile of the tomb of Tutankhamun
was given to the people of Egypt by the Factum Foundation,
14th November 2012.

A selection of stories about

**CULTURAL PRESERVATION,
INNOVATION
COLLABORATION,
TECHNOLOGY TRANSFER,
DIGITAL DOCUMENTATION
DIGITAL RESTORATION
AND RE-MATERIALISATION**

**carried out by
Factum Foundation**

The Factum Foundation 9

Introduction

What is a facsimile?	15
What are the reasons for making a facsimile?	15
Why is digital technology important for conservation?	17
Facsimiles for replacement	17

Projects, digital restoration and technology development

The completed facsimile of the tomb of Tutankhamun at the Valley of the Kings	19
The Theban Necropolis Preservation Initiative	25
Recording the Seti I sarcophagus at Sir John Soane's Museum	29
Digitisation and restoration of manuscripts at the State Archives in Daghestan	31
Digitising the mosque and mausoleum at Kala-Koreysh	33
Ashurnasirpal II's throne room, Nimrud	39
Nahr el Kalb	41
New training initiatives - projects in preparation	43
Polittico Griffoni	47
Teschen Table	51
Cluny Christ	57
Ancient Oak at Windsor	61
Wenzel Jamnitzer - Polyhedral Monuments	65
Digital Restoration: Tutankhamun and Seti I	69
Digital Restoration: Cerralbo tapestry	71
Digital Restoration: San Baudelio de Berlanga	75
Digital Restoration: Sala Bologna	77
Hereford Mappa Mundi	79
Gough Map & Selden Map at the Bodleian, London	83
Borsano Map at the Biblioteca Nacional, Madrid	83
Strawberry Hill House	87
Cochno Stone	91
Lucida 3D Scanner	93
Replica 360 Recto Verso Scanning Table	101
Tactile Photography and Synaesthesia	105
Veronica Chorographic Scanner	107
Book Scanner designed to record the miniature	111
Offiziolo by Giovanni Pietro Birago	111
Lucida Lab Milano	114
The Factum Foundation and Open Care Lucida Competition	115
Reintegration of missing fragments	117

Conclusion 119

How to contribute 123

All projects carried out by the Factum Foundation are collaborative and there are many people to thank. This is not the place to name everyone but some people have done a great deal to make all this work possible; Charlotte Skene Catling, Tarek Waly, Simon Schaffer, Adrian Cussins, Pasquale Gagliardi, Fondazione Giorgio Cini, Bruno Latour, Jerry Brotton, Roberto Terra, Cat Warsi, Luke Tchalenko, John Tchalenko, Manuela Mena, Norman Rosenthal, The Griffith Institute, Don Oreste, Elena Arias, Polina Filippova, Emma Duncan, Jacob Rothschild, Fabia Bromofsky, Ziyavudin Magomedov, Natalia Izosimova, Rachid Koraiichi, Andrew Edmunds, Colin and Charlotte Franklin, Ed Maggs, the Hereford Mappa Mundi Trust, Rosemary Firman, Philip Hewat-Jaboor, Helen Dorey, Nazy Vassegh, Peter Glidewell, Tom Stuart Smith, Purdy Rubin, Fernando Caruncho, Betty Guereta, Michael Hoppen, Matthias Lietner, Jim Moran, Kathelin Grey, Bassam Daghestani, George Richards, David Coulson, Jeffrey Berman, Veronica Berman, Maria Golia, Anthony Sattin, Johnny Allen, Nicholas Penny, Mark Leithauser, Carole Patey, Michael Snowdin, Silvia Davoli, Bill Sherman, Nico Schwartz, Julian Rothenstein, George Richards, Fady Jameel, Ahmed Mater, Larry Keith, Mark Norman, and many others who care about the preservation of the past.

In memory of Peter de Francia, John Golding, Jane Cameron and Piers Wardle who continue to inspire and have set uncompromising standards.

And, of course, everyone at Factum Arte who works tirelessly to support the Factum Foundation and turn dreams into a reality.

The Factum Foundation



Top: Leonardo's *Last Supper* in the refectory of the convent of Santa Maria delle Grazie, Milan during colour and 3D recording in 2015.
Bottom: Veronese's vast painting, *The Wedding At Cana* hangs in the Musée du Louvre. The visitors, filling the room are all trying to get a glimpse of the *Mona Lisa*.

Museums were conceived as places of wonder, a literal ark that brought together the natural and cultural worlds. As they developed, art museums became places in which aesthetic objects were conserved and displayed with taste. But in the renaissance we are living through now, technology is creating both a new type of space and a new type of connoisseur, one who 'preserves the fire' by focussing on the dynamic nature of originality, where the object is recast as a complex subject.

Institutions and individuals have been the historic patrons of high-profile restoration projects. Until now, they have been less willing to contribute to preservation projects where the emphasis has been on documentation and nurturing a deeper understanding of works of art. This is changing as technology reveals how restoration projects are rooted in their own time and often significantly alter works of art. Imagine Michelangelo walking into the Sistine Chapel today; would he celebrate or be horrified? Picture Leonardo looking at the *Last Supper* in Milan or Veronese in the Louvre standing in front of a painting he made on the wall of a monastic refectory in Venice now being visited by an estimated 10 million people a year in Paris.

Technology is providing a new environment where forensic accuracy and 'digital restoration' can create the space for experts from many different disciplines to work together. Digital and physical artisans are working alongside historians, scientists, restorers, museum directors, dealers, collectors, curators and many others. Before the work of art is turned into a partial reproduction of itself through physical interventions, there are many different points of view and interested parties to be satisfied. In this environment a new type of digital scholarship is emerging; one that celebrates the excitement of curiosity and communication.

The Fondazione Giorgio Cini, the extraordinary cultural institution that occupies the Island of San Giorgio Maggiore in the heart of Venice (Factum's close collaborator since 2006) uses the quotation about ashes and fire in all their communication. Both the Fondazione Giorgio Cini and the Factum Foundation's work is dedicated to kindling the flame; to the application of digital and physical technologies to reveal how we relate to, learn from and understand the articulate evidence we have inherited from the past.

The Factum Foundation is seeking enlightened philanthropists to finance the development of this approach in order to make a positive impact on digital preservation. Aby Warburg transformed art history in the C20th and the Warburg Institute carries his name long after the glorious reputation of the banking dynasty faded. Something similar is possible now! The Foundation needs funding for its core works as well as a number of individual projects. The central project, The Theban Necropolis Preservation Initiative, aims to record and replicate the tombs in the Valley of the Kings. All funding will be used to enable the research, encourage development and provide the equipment required for the technology to work in practice. It will also ensure that the skills required to use the equipment are transferred to local people.



The re-materialisation of Caravaggio's *Nativity with Saint Francis and Saint Lawrence* was a "performance" of a lost painting by Caravaggio carried out by Factum Arte working with Peter Glidewell, Ballandi Multimedia and Sky TV.

Since the successful completion of this work Factum Foundation is now in discussion with Peter Glidewell and Ballandi Multimedia to develop a new series about paintings that have been lost or destroyed since 1900. The new model that is being developed not only allows complex and diverse stories to be told in detail, it also provides the funding to carry out digital recording, archiving and, where relevant, the re-materialisation of works of art.

Recently Oxford and Harvard Universities were associated with the Institute of Digital Archaeology's (IDA) copy of the Triumphal Arch at Palmyra. The result, when installed in Trafalgar Square, demonstrated the need to clarify the terms being used and the claims being made. IDA's 'exact copy' was not accurate in terms of scale or material, but more importantly, it was not true in terms of the language of decoration and architectural ornament. The reality was not an exact facsimile but a mock-up, with the quality of a stage set. Yale University is setting up a new, well-funded, Institute for the Preservation of Cultural Heritage and recently gave away 3D printed pieces of Palmyra, resembling cheaply available souvenirs at Davos, in a similar publicity stunt. The Factum Foundation prefers a practical approach that stays closely in touch with work on the ground. We focus on projects that benefit both the science of conservation and the local community through the development of hardware and software that pushes the boundaries of what is possible in terms of information capture and output. All the money we generate is spent on applying this technology and ensuring the data gets to the people who need it in a form they can freely access. Our reputation rests on the quality of our facsimiles. Our facsimiles are dependent on the quality and diversity of the data we record.

An understanding of the decisions and transformations that happen during the recording, processing, archiving and re-materialisation of an object is essential. In an age when digital and physical artisans are working together, this requires the emphasis be placed on building bridges between different skills and professional disciplines; between the traditional arts that celebrate the transmission of knowledge through manual repetition and the digital arts that express the same understanding through algorithms and electronic engineering.

The facsimiles of the Table of Teschen or the Cluny Christ are made through a deep understanding of both input and output technologies. The Cluny Christ is made from wood and resin using a mixture of additive and subtractive manufacturing processes involving CNC milling on a 7 axis robot and high-resolution 3D printing (laser sintering). While they are amazing technologies, neither of these processes is individually capable of making an object that has the qualities of the C12th figure that now hangs in the Musée Cluny in Paris. This is dependent on a working knowledge of materials, the skills of a fully trained conservator, the eyes and hands of different artists and the guidance of people who have studied these works over many years. The Table of Teschen is a similar story. So is the facsimile of the Tomb of Tutankhamun, the re-creation of Caravaggio's *Nativity with San Lorenzo and St. Francis*, the work on the grave-stones in Kala Koreysh or any of the projects that have been completed by the Factum Foundation (often working alongside the team from Factum Arte).

All artefacts are complex subjects that need to be studied. When they are reduced to discrete aesthetic objects they lose a significant part of their meaning. The Factum Foundation is dedicated to keeping objects alive – to "the preservation of fire rather than the worship of ashes".



The first rendering of the inside of Seti I's sarcophagus following its recording at Sir John Soane's Museum, London.

Factum Foundation's work takes many forms:

- **The development and application of specially designed technologies for cultural applications.**
- **Building bridges between digital technologies and traditional manual skills.**
- **Using facsimiles as a means of protecting works of art, especially those that were meant to last but not to be visited.**
- **Changing attitudes to the relationship between originality and authenticity.**
- **Revealing the stories and ideas contained within things.**
- **Transferring skills and technology to local communities.**
- **Education and dissemination of the importance of digital preservation.**



A facsimile of a polychrome C12th wooden Christ from the Auvergne in the collection of the Musée de Cluny, Musée National de Moyen Âge in Paris.

What is a facsimile?

The Latin '*fac simile*' literally means 'to make alike'. It differs in definition from other words used to describe reproduction in that it is not attempting merely to copy, but rather to replicate the source as accurately as possible in terms of colour, texture, scale and other material properties. Facsimile is a misunderstood word, which until recently, often provoked an emotional and negative response; usually as a result of the poor quality of work paraded under that name.

Unlike other types of reproduction, a facsimile is capable of adding meaning to the original. It was possible to digitise the burial chamber of Tutankhamun in 2009, re-materialise the data in 3D and colour in Madrid and make an accurate 1:1 facsimile, almost identical to the original at normal viewing distances and install it at the entrance of the Valley of the Kings in 2014. This is evidence of the quality of the data recorded.

To appreciate the quality and importance of a facsimile it is necessary to understand that a work of art is not fixed and static but in a dynamic process of change that can be slowed down or accelerated by our actions and forces beyond our control. Since the recording in 2009, the tomb of Tutankhamun has been conserved and cleaned by the Getty Conservation Institute. Factum's facsimile is a true record of the appearance of the tomb in 2009 with the lighting it had at that time. The same is true of all the facsimiles made in Factum Arte's workshops. The originals often change in unpredictable ways. The *Schwittersshytte*, by Kurt Schwitters, was in a hut in an advanced state of decay when it was recorded in 2009. It was subsequently dismantled, restored and moved into a purpose built space in the Romsdalmuseet where it now forms part of a museum display about Kurt Schwitters.

What are the reasons for making a facsimile?

Be it a painting, a sculpture or a heritage site, there are a growing number of reasons for making a facsimile. The facsimile of Veronese's *Wedding at Cana* allows one to see an almost perfect replica of the painting in its original context in Venice while the original work remains in the Louvre. Observing the painting in the space for which it was conceived by the artist results in a more authentic experience and a new form of repatriation in which both the Cini and the Louvre benefit. Facsimiles can unify the scattered elements of an artwork, reassemble collections, allow public access to inaccessible sites, remake damaged or lost objects, provide research and dissemination through exhibitions and allow a new approach to museum loans.

The movement of painting and works from one museum to another demands objectively accurate condition reports. These are generally done in a subjective way by looking and taking notes. A 3D scan of the surface coupled with high-resolution photography provides an objectively accurate record of the surface. A before and after scan can show changes to the surface in an objectively accurate and verifiable way.



There has been a lot of information in the media about the role of 3D scanning and printing systems in the rebuilding of sites destroyed in iconoclastic attacks. Most of these have focused on Palmyra and have been based on an image found on the internet (top). The Factum Foundation decided to clarify the issue and reveal what is possible and at what cost. Irene Gaume, a highly skilled 3D modeler was given a selection of images and asked to model a section of low relief decorative carving. The Foundation has access to powerful computers and software. The resolution of the 3D modeling is impressive (bottom) and can be transformed from virtual to physical data. The 3D modeling took almost 180 hours- the CNC milling took slightly less time. While it is clear that with highly trained skilled modelers you can recreate lost objects they will always be an interpretation based on the available data. It is far more important to concentrate the limited resources available to heritage projects on recording the artefacts before they are destroyed.

Why is digital technology important for conservation?

Objectively accurate, forensic evidence that can be viewed in different ways is essential for making a meaningful facsimile. Ideally objects should be recorded using 3D technologies and photography that works on the visible and invisible spectrum of light. It is also important to gather together historical records and photographs made during previous restorations.

The Factum Foundation was created to promote and develop digital technology for the recording, documentation, archiving and dissemination of cultural heritage. The preparation of freely available, interactive, multi-layered archives is an essential part of this work. They are essentially 'digital passports' for works of art at a specific moment in time. Digital 'restoration' is a rapidly developing approach to non-contact preservation allowing various opinions to be projected onto a work of art without interfering with the original.

Facsimiles for replacement

Should all works that are granted an Export License be fully-recorded and replicated?

One use of facsimiles currently under discussion by the Factum Foundation, is in cases where families and dealers decide to sell works of art and an export licence is required. Export licenses are required for works over 50 years old and deemed to be of national or cultural significance. In the UK around 25-50 objects are refused an export license each year out of a total of approximately 13,000 applications (covering around 55,000 objects), illustrating the sheer number of cultural artefacts that leave the UK annually.

Over the past five years the UK has lost many seminal works because a buyer could not be found to keep it in the country, including Nicolas Poussin's *Ordination* (£15,000,000), Picasso's *Child with a Dove* (£50,000,000), Raphael's *Head of a Young Apostle* (£29,721,250) and Napoleon Bonaparte's Death Mask (£175,100). The Factum Foundation feels that all works leaving the country should be fully recorded and archived.

If there was a change in the law to require vendors to pay for the high-resolution digital recording of all works of art that are granted export licenses, it would quickly grow to form a vast archive of data. The data would remain in the UK, copyright would belong to the purchaser (unless it is a contemporary work with the copyright already ascribed), but the information would be freely available for academic and research purposes. It should also be a stipulation that one faithful facsimile could be made to replace the original and be presented in its original environment (as was the case with the Teschen Table – page 51). It is hard to be precise about exact costs as each work of art requires different treatment. £2500 per sq meter is normally enough for the high-resolution surface and colour recording of a painting. The cost of the production of facsimiles can vary greatly. Compared to the value placed upon original works of art of importance these costs are negligible and over time provide an objective archive against which the condition of the work can be compared with forensic accuracy.



Installing the facsimile of the burial chamber of Tutankhamun

The completed facsimile of the tomb of Tutankhamun installed at the entrance to the Valley of the Kings



The entrance to the facsimile of the tomb of Tutankhamun with Stoppelaere house in the distance.

Tutankhamun's burial chamber was designed to last for eternity, but not to be visited. It is currently undergoing cleaning and conservation work that is being carried out by the Getty Conservation Institute. It is essential that the fabric of the tomb can be studied in depth and understood, as well as receiving the care it needs. It is equally important that it is fully documented to facilitate accurate monitoring of the conditions within the tomb and the changes that occur. Simultaneously, it is necessary to attract visitors to Luxor, and the tomb of Tutankhamun is the most famous in the Valley of the Kings. It is clear that the tomb has suffered significant damage as a result of regular visitors since its discovery in 1922 and through conservation attempts to stabilize the fragile painted surface of the burial chamber.

The Factum Foundation's solution is the Theban Necropolis Preservation Initiative that is being carried out with the University of Basel and the Ministry of Antiquities (see page 25). Phase one of this initiative was the production of an exact facsimile of the tomb of Tutankhamun. This replica is now installed next to Howard Carter's house, at the entrance

to the Valley of the Kings (April 2014), close to the original. The facsimile serves to relieve pressure from excessive visitor numbers in the original tomb, but the data also offers new opportunities for study and recently led to the possible discovery of further chambers behind the north wall of the burial chamber. As a public attraction, the facsimile is helping visitors understand the damage they cause, and the complexity of preserving fragile sites ensuring their long-term preservation. Such initiatives are leading to a re-negotiation of the relationship between the original and the authentic. Several years ago the prevailing tourist reaction revealed a deep-rooted prejudice against visiting a facsimile. The reaction of almost everyone to the facsimile of Tutankhamun is that this fusion of art, science and digital technology, re-created with forensic accuracy, can actually lead to an enhanced visitor experience. Carter's House and the Replica Tomb is a new visitor attraction that is proving successful.

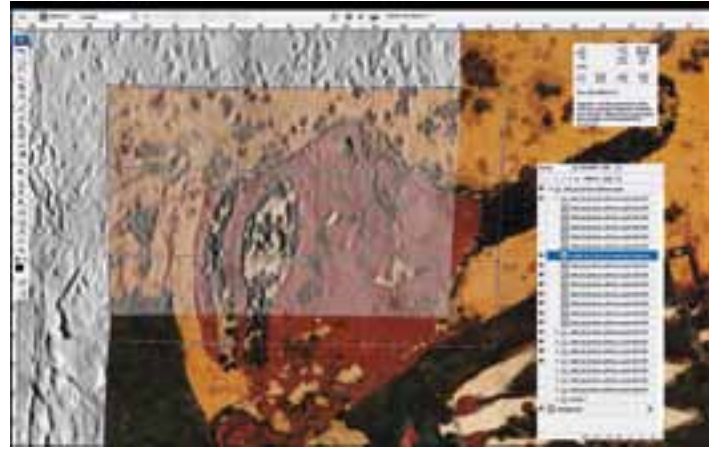



To the Valley of the Kings



Stoppelaere house is an imposing mud brick building standing on a steep-sided hill at the entrance to the Valley of the Kings. It was designed by the great Egyptian architect Hassan Fathy but has been unused for many years as the hill was slowly eroding, threatening the stability of the building. In a project funded by the Factum Foundation, Tarek Waly has devised an ingenious solution to bind the foundations of the building together with a band of reinforced concrete that surrounds the house below ground level. The first stage of the work is complete and the next phase - the conversion of the building into a 3D scanning and training centre is under way. It will be finished by the end of the year and the training of local residents in the skills involved in 3D scanning, composite photography, photogrammetry and archiving will begin.

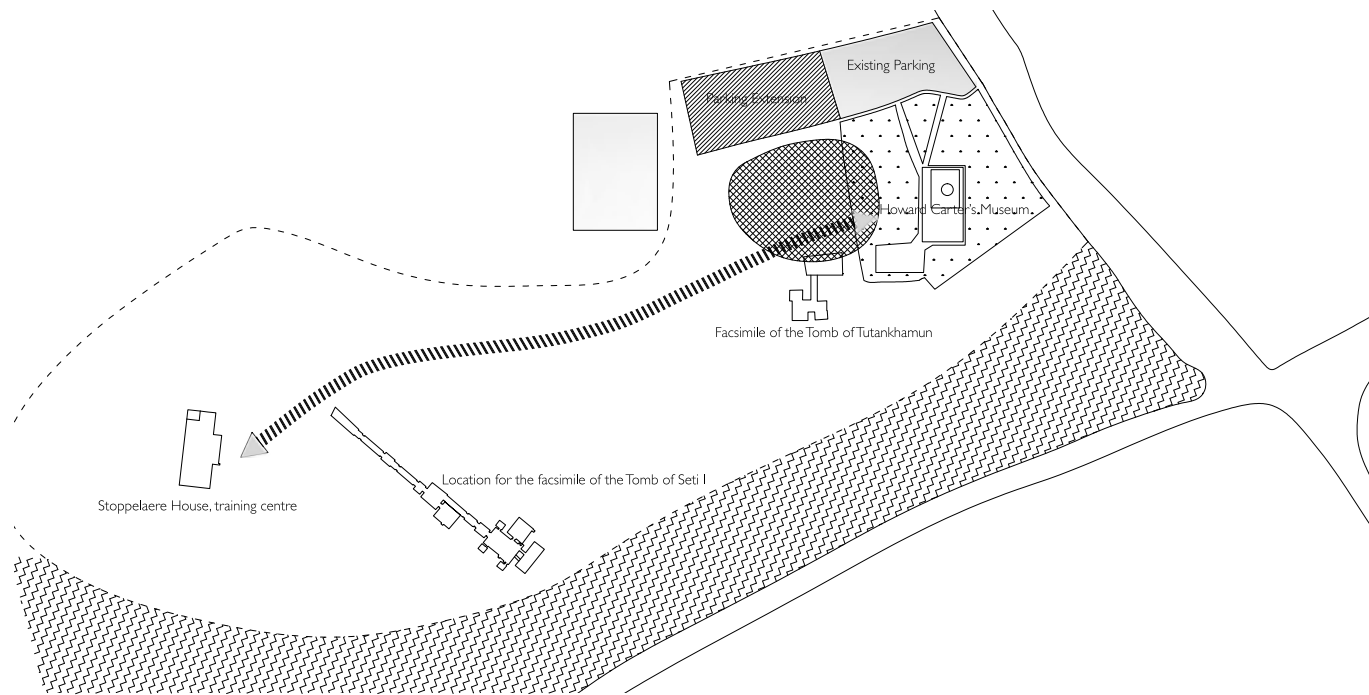

A map showing the proposed location of the facsimile of the tomb of Seti I in relation to the existing facsimile of Tutankhamun's tomb. At the top of the map the proposed site for the workshops in which the facsimile will be made, if the funds can be raised to complete this stage of the work.

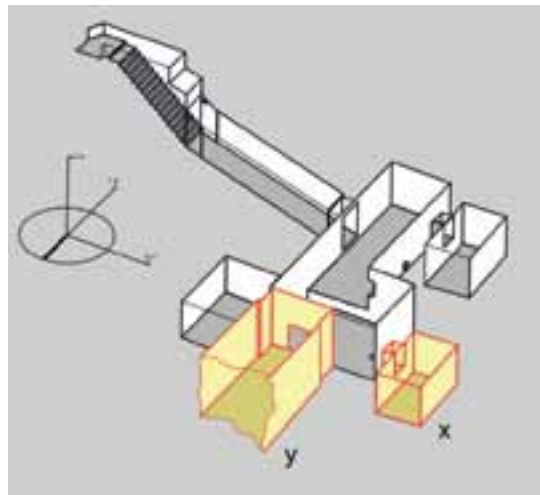

The plan of the tomb of Tutankhamun showing the hidden rooms proposed by Nicholas Reeves.



Aliaa Ismail leading a training session with Mahmoud Salem, Abdu El Reheem Ghaba and Moussa Sayd Mohamed in the temporary training centre near Medinet Habu temple.

A possible discovery based on Factum Foundation's high-resolution data

The high-resolution data acquired during the recording of the burial chamber of Tutankhamun was made freely available on the web by Factum Arte, with permission from Zahi Hawass, the then Secretary General of the Supreme Council of Antiquities. It was prepared so that the walls of the burial chamber could be studied at high magnification as colour photographic images and as a tonal rendering of the surface texture. Working in New York, the Egyptologist Nicholas Reeves studied the data and has proposed

an exciting hypothesis: he suggests that the data reveals a blocked up door leading to what he suggests may be the tomb of Nefertiti. Investigations are currently taking place using thermal tomography and ground penetrating radar to examine if there are voids behind the walls of the burial chamber. Initial results are proving positive but regardless of the outcome, the story highlights the valuable opportunities made possible by progressive methods of high-resolution documentation and dissemination.



A scene showing Osiris greeting Seti I under the watchful eye of Horus, from the tomb of Seti I.

Following the successful installation of an exact facsimile of the burial chamber of Tutankhamun in the entrance of the Valley of the Kings in 2014, the aim is now to create the infrastructure for sustainable heritage management that uses the justified fame of the Theban necropolis, the visitor numbers and public interest in preservation to create a long-term, self-financing structure that benefits the local community.

This project is being led by the Factum Foundation and the University of Basel, working in conjunction with the Ministry of Antiquities and the Waly Centre for Architecture and Heritage. Work started in April 2016 and will result in the restoration of a prominent building by Hassan Fathy, the complete recording of the tomb of Seti I and the training of local people to carry out the recording, processing and archiving of the data.

This project will run for the next five years, and if the money can be found, it will also result in the construction of new workshops and a visitor centre where the complete facsimile of the Tomb of Seti I will be made by local teams, equipped and trained by the Factum Foundation. The tomb of Seti I is one of the largest, most lavishly decorated and important tombs in the Valley, but it has been closed to the public for conservation reasons since the late 1980s. It is also reputed to contain 'hidden rooms'.

Stoppelaere House, a mud-brick building by Hassan Fathy is a landmark at the entrance to the Valley of the Kings, seen by every visitor that passes. It is being restored by the Factum Foundation and will be used as a 3D Scanning and Training Centre. The restoration work is being carried out by Tarek Waly (Hassan



Top: Carlos Bayod and Aliaa Ismail in the *Hall of Beauties*, Tomb of Seti I, 2016. Bottom: A rendering of one of the walls in the *Hall of Beauties*.



The Sarcophagus room in the tomb of Seti I. Inset: A team from Factum Arte demonstrating that it was possible to 3D scan the relief carving in the tomb in 2001.

Fathy's assistant for many years) using local craftsmen. Work started in late April 2016 and is scheduled to be completed by the end of the year. The aim is to set a high standard for the preservation of this mud-brick building and to stimulate the desire to preserve other works by this great Egyptian architect.

The Centre is being fully equipped by the Factum Foundation with the latest technologies required for high-resolution 3D recording, composite photography, processing and archiving. A team from Luxor's West Bank will be trained in all aspects of this work and will take full control of the centre when the recording of the tomb of Seti I is complete. The centre will be managed by Aliaa Ismail (a graduate from the American University in Cairo), who has just completed eighteen months of training in Factum Arte, Madrid.

The recording of the complete tomb of Seti I also started in April. The 3D scanning began in the *Hall of Beauties* using two Lucida scanners (designed for the Factum Foundation by Manuel Franquelo) and composite photography. It is anticipated that other technologies, especially high-resolution photogrammetry, will be used as the software is perfected. The recording work will last for 3 years.

This project is rethinking effective cultural heritage management and providing the Egyptians with the material infrastructure to promote, study and preserve their cultural treasures.



The 16th of October 2017 will mark the 200th anniversary of Giovanni Battista Belzoni's discovery of the tomb of Seti I in the Valley of the Kings. In the years following its discovery, sections of the decoration were removed and there are now hundreds of fragments in museums and collections around the world. The largest are in the Musée du Louvre in Paris and the Archaeological Museum in Florence. There are also a large number of smaller fragments that were found in the rubble outside the tomb by a team from the University of Basel. The intention is to record and re-integrate all the fragments to make the facsimile more complete than the original tomb. The 3D scanning of the Sarcophagus in Sir John Soane's Museum marked the start of the work to record all the fragments.

The Sarcophagus was brought to London, exhibited at the Egyptian Halls on Piccadilly and sold to Sir John Soane in 1824, after it was rejected by the British Museum. The first tests to make a 3D recording of the white alabaster sarcophagus took place in 2001 during a conference on Factum Arte's work in the tomb of Seti I. But the translucent nature of the material meant that the data was noisy and meaningless. Fifteen years later, the Factum Foundation used photogrammetry to record the sarcophagus at a resolution of about one tenth of a millimetre. Photogrammetry is a process which extracts three-dimensional data from two-dimensional images using feature mapping and a range of algorithms. Working in the confined space of the crypt in Sir John Soane's museum, over 4,500 images were taken with a Canon 5DSR (50 megapixel) over a five-day period. The team employed a motorised rig onto which the camera was mounted, with two flashes mounted at a 45° angle to

spread an even light on the exterior surface. The interior of the sarcophagus was difficult to reach and was recorded using a hand-held setup.

These images are now being stitched together, in collaboration with Autodesk and Capturing Reality, to form a 3D model that will facilitate an in-depth study of the surface and shape of the sarcophagus. The plan is to make a facsimile of the sarcophagus that will eventually be installed in the facsimile of the tomb at the entrance to the Valley of the Kings.

The data will also be used to digitally restore the sarcophagus to the way it looked at the time it entered Soane's collection. Joseph Gandy's watercolours show it as a white alabaster form with blue inlay, but time, the English climate, and attempts to conserve it have changed its appearance.

This collaboration demonstrates the close relationship that has been developed between the museum and the Factum Foundation. The data gathered in the recording will be useful for academics studying, amongst other things, the texts inscribed in hieroglyphics on the surface. It will also be processed into a 3D model, which will join a series of Soane's architectural models, as a part of the 'Digital Soane' project to create a publicly-accessible interactive website to be launched in late 2016.

This project aims to demonstrate that 3D scanning and 3D printing are C21st technologies that can assist in the preservation of great works of art, without inflicting damage on the original object.

Digitisation and restoration of manuscripts at the State Archives in Daghestan

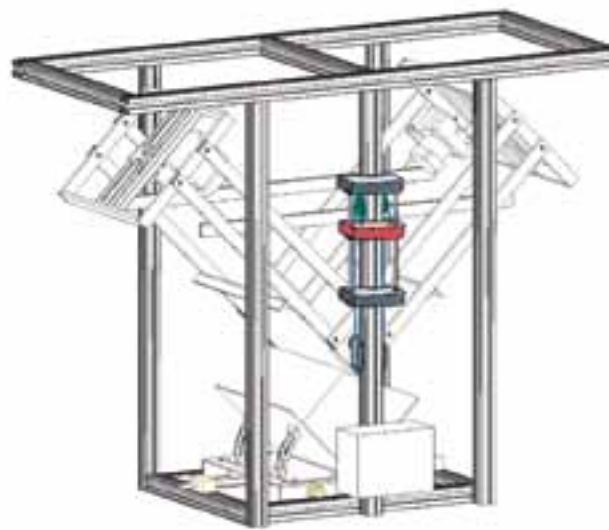

Top: Bassam Dagestani inspecting an early copy of the Qur'an in the Institute of History, Archaeology and Ethnography of the Russian Academy of Sciences (Makhachkala) with Makhach Musaev, Director of the IHAE.

Centre: Manuscripts stacked on shelves in the Institute. These volumes will be digitised and stored in acid free boxes to protect them prior to any treatment.

Bottom: The Factum Foundation is now building the first two digitisation systems (one fixed and the other portable), that will be delivered to Daghestan in September. These systems are designed to be robust and easy to use but capable of fast high-resolution recording. The scanners will be housed inside the IHAE next to a restoration workshop that will be designed and equipped by the Juma al Majid Centre for Culture and Heritage, Dubai. The work in Daghestan has been made possible through the generosity and practical support of the Peri Foundation.



The Factum Foundation is working with the Peri Foundation (Russia) and the Juma Al Majid Centre for Culture and Heritage (Dubai) to digitise and restore a collection of over 3,000 Islamic manuscripts from the 11th to the 20th centuries, as well as over 5,000 documents from the 17th to 20th centuries in Daghestan (Russian Federation). The archive is held by the Institute of History, Archaeology and Ethnography (IHAE) of the Russian Academy of Sciences (Makhachkala), and contains documents of both artistic and historical importance. The Factum Foundation will be providing the recording and archiving framework while the Juma Al Majid Centre will provide the equipment and skills required to restore and protect the physical books. Training and nurturing of local talent will be undertaken by both the Factum Foundation and the Juma Al Majid Centre and will result in the creation of a sustainable Centre for Manuscript

Digitisation and Restoration in Makhachkala. The Peri Foundation have funded and are controlling all aspects of the work in the archive. It is essential that these projects are well managed and achieve results at or above international library standards. In Daghestan, a country with a rich Islamic heritage, there may be as many as 30,000 manuscripts distributed amongst the private collections of Islamic scholars (and their families), mosques and madrassas –we will work with the Peri Foundation and IHAE to digitise these books and make them accessible.

The data created throughout the duration of the project will be available for study to scholars around the world and we hope it will result in the revitalisation of interest in the history and culture of the northern Caucasus.



A rendering of one of the carved gravestones from inside the mausoleum.



The abandoned village of Kala-Koreysh in the mountains of southern Dagestan is home to one resident: the caretaker of the fortress-mosque of the same name lives alone with no running water and a limited electricity. The last villagers left in the 1940s during the repression under the Soviet rule in the Caucasus, following a long period of decline that began in the C14th, and which was accelerated in the C18th as people moved from the mountains to the plains. Nevertheless, Kala-Koreysh was once an important religious and administrative centre. From the C8th it was the capital of the newly-

conquered Arab region of Qaytag, it would have been at the forefront of the cultural and religious life of the region and its mosque one of the most significant. It was partly destroyed in the C20th: only two fragments and a photograph of its spectacular carved C12th-13th *mihrab* survive. The carved wooden doors of the mosque were taken to the Academy of Sciences in Makhachkala, but at least thirty-nine tombstones, carved fragments and a number of sarcophagi remain.



Detail of the painted relief carving on one of the four gravestones inside the Mausoleum at Kala Koreysh. Opposite is a detail of the same stone milled on a 3 axis CNC and cast in plaster.



The Factum Foundation and the Peri Foundation are now working with local residents to record some of the carved decorative details that are often in perilous positions as the buildings collapse.



Shamil Gadzhidadaev using his drone to accurately record the topography of the mausoleum and Mosque at Kala Koreysh.

The aim of this project is threefold:

1. To record the doors in Makhachkala and the low-relief carvings on tombstones and sarcophagi at the fortress-mosque.
2. To use the data recorded at the mosque in meaningful ways that will lead to a revival in interest for Daghestani culture in general and in Kala-Koreysh specifically as a centre of religious tolerance.
3. To train a number of people from Daghestan in the use of 3D scanning and photography technologies.

Between the 10th of May and the beginning of June 2016 a group from the Factum Foundation started the 3D and photographic recording at Kala Koreysh, working alongside two photographers from the region; Gennady Viktorov and Shamil Gadzhidadaev.

Before arriving in Kala Koreysh, the team had already been in Makhachkala and completed the high-resolution photogrammetric recording of the doors of the mosque in the store-rooms by the Museum of History and Archaeology.

In Kala Koreysh they made a plan of the site dividing it into four areas; the eastern graveyard, The Mausoleum, the western Graveyard and the Mosque. All the carved surfaces

were recorded using high-resolution photogrammetry. Some of the stones are in very bad condition and require urgent digitisation before the surface completely exfoliates. Several are broken and were recorded as fragments that will be digitally restored to facilitate study. There is also a carved sarcophagus that was recorded in 3D and another burial area that was fully photographed.

The entire site was 3D scanned using a computer-controlled drone with the aim to produce a vast photogrammetric recording with a resolution of 1.7 cm per pixel.

The Factum Foundation's collaboration with the Peri foundation started in November 2015 and has already resulted in the training of Gennady Viktorov and Shamil Gadzhidadaev and the complete digital recording of Kala Koreysh. Work has already started to build the equipment for the state archives and a four way agreement has been agreed with the Juma Al Majid Centre for Culture and Heritage in Dubai that will result in the digital recording and preservation of the manuscripts.



One of the Lamassu from the British Museum recorded by Factum Arte in 2005. The final facsimile is made of scagliola.



In 2015, the site in northern Iraq that contained the ruins of the Assyrian city of Nimrud was attacked by the group calling itself Islamic State. Everything that remained, both above and under the ground, was either destroyed or seriously damaged. An earlier project by Factum Arte (before the formation of the Factum Foundation) involved the reconstruction of the eastern end of the throne room of Ashurnasirpal II in the Northwest Palace in Nimrud. It was intended for an exhibition that never happened, but a team from Factum Arte completed high-resolution 3D scans and photographic documentation of the sculptures and relief panels that had been removed from their original location in 1848/9 by Austin Henry Layard. They were originally brought to the British Museum where the majority remain but in a familiar migration of museum objects there are now parts of this narrative cycle of relief carvings in the Pergamon (Berlin), the Staatliche Kunstsammlungen (Dresden), The Sackler Collection (Harvard), and The Art Museum (Princeton).

In 2005 Factum Arte was granted permission by the Iraqi government to record the fragments left on site in Nimrud and other known fragments in Mosul and Baghdad. This trip was postponed by the Iraqi Ministry of Antiquities and eventually

cancelled as a result of the war and hostage taking in the area. The archaeological evidence of the past contained in this important site is now lost to the world forever. Had we been able to make a high-resolution recordings in colour and 3D, something meaningful would remain in digital form. It is imperative that documentation is given a central role in heritage conservation; now more than ever. This work should be done in times of peace rather than as a knee-jerk reaction to war and iconoclastic destruction.

In early 2014 plaster casts of the works recorded in the British Museum were donated to the Ashurbanipal Library Project in Mosul. They were shipped to Mosul via Turkey and arrived on 1st May. Soon after, IS took control of the city. At the time of writing it is not known what has happened to these casts, it is believed they have been destroyed. If this is the case they will be replaced with new casts when the University of Mosul is able to complete the library project that is devoted to bringing together a great cuneiform library for study and dissemination of the information contained in the millions of cuneiform tablets that remain.



3D Rendering of the Stela to Esarhaddon 688 - 699 BC. Recorded by Alex Peck on May 15th, 2015 using only a 35mm camera and a tripod.

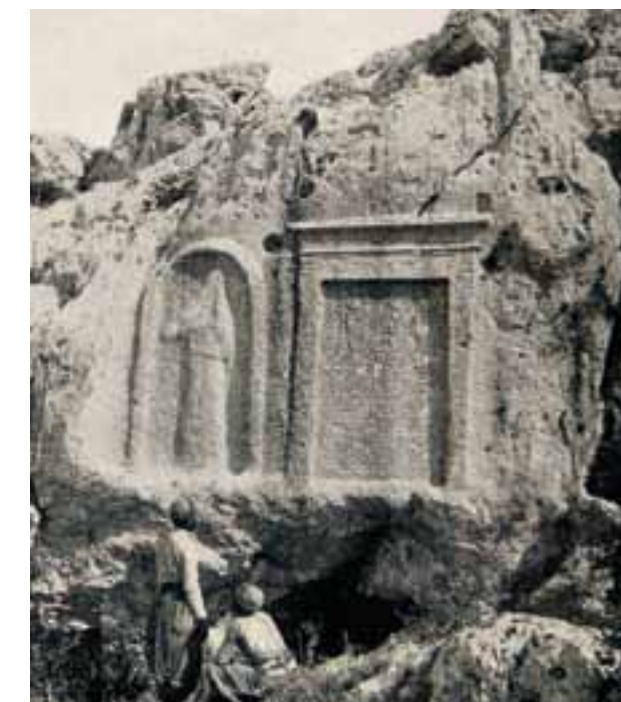

The ability to extract 3D information from 2D images is revolutionizing the way in which we can document cultural heritage. Photogrammetry, a method of taking multiple high-resolution images of an object that are subsequently aligned and processed to form a 3D model, provides an opportunity to quickly record inaccessible and vulnerable sites with a high level of accuracy. Due to recent developments in software it is now possible to carry out photographic recording of vulnerable sites using only a good SLR digital camera, a tripod, a linear guide and a ring flash. It is essential that this recording is done systematically and in a logical way. Photogrammetry offers a low cost, highly portable, non-contact method of recording 3D data in the field that serves as a proactive solution to looming, and very serious, threats. Once the information is captured it can be stored and processed at a later date. The processing is still time consuming and requires expensive software and computers. The Factum Foundation has recently announced an agreement with Autodesk to work together to ensure the data can be processed on server farms on the Cloud. At the same time, we are working with Capturing Reality to ensure their algorithms can be used when the highest resolution data is required.

The Factum Foundation secured an agreement with Lebanon's Ministry of Antiquities and APSAD (a local 'not-for-profit' dedicated to the preservation of Lebanon's heritage) and implemented a pilot project to record 10 stelae (Ancient

Egyptian, Neo-Assyrian and Neo-Babylonian) at Nahr El Kalb, a UNESCO 'Memory of the World' site north of Beirut. In a timed trial, two stelae were recorded and processed with great success. Later this year the remaining stelae will be recorded to ensure that a memory of these rapidly deteriorating carvings remains.

Photogrammetry has rapidly established itself as the most important recording system when funding is limited and the transportation of fragile equipment is not possible. The improvement of the algorithms and the development of processing using server farms on the Cloud will establish photogrammetry as the dominant form of 3D scanning for cultural heritage over the coming years. The Factum Foundation understands the problems of working on the ground in different environments and is committed to supplying the equipment and training local operators to carry out the photography in the correct way to allow for, storing the data and then processing it at the highest resolution and in the most efficient way when it is needed.

The vision is to inspire and organise a movement of mass cultural heritage documentation. Eventually, anyone equipped with a decent camera and basic training will be able to partake in preserving our shared cultural heritage by contributing to a vast archive of high-resolution data, ready to be processed if and when the time comes.



The old towns of Mecca and Medina have almost disappeared. The heart of the old town of Jeddah still exists. Community Jameel is working with the Prince's School of Traditional Arts, Ahmed Angawi and the local community to ensure that the extraordinary wooden buildings remain. The Factum Foundation is now working towards a collaboration with Community Jameel to demonstrate the role that technology can play in both recording the architecture and its language of ornament and in creating a workshop where additive and subtractive manufacturing processes can be integrated with the traditional arts that are essential to preserve these buildings.



One of 3 sites in Libya's Acacus Mountains World Heritage Site irreparably damaged with spray paint.



Large female petroglyphs, Ennedi Plateau, Chad. A pilot training session will take place to record this and other sites on the Ennedi Plateau, before the end of 2016.



Morocco's Director of Culture holding broken fragments of a 5000 year old panel of engravings destroyed by thieves who tried to remove it. Atlas Mountains foothills, south west Morocco.

Over the past two years the Factum Foundation has been forging a close relationship with The Trust for African Rock Art (TARA). TARA, run by David Coulson has photographically documented a vast amount of 'rock art' sites across the African continent. Its archives are now kept with the British Museum and available to the public. While TARA has achieved a great deal there is still much more to be done. The Factum Foundation is working with TARA on the application of photogrammetry to ensure that the petroglyphs, drawings and carvings are recorded in colour

and 3D at high resolution. Projects are currently being organised in Chad and Nigeria. In each case the aim is to supply the equipment and train local operators to carry out the photography in correct way so that it can be processed with photogrammetric software and correctly archived.

If recorded correctly fragments like the smashed stone illustrated above could be digitally reconstructed to preserve the information they contain.

THERE IS NO FUTURE WITHOUT A PAST



There is No Future Without a Past is an animation by Matteo Manzini, produced by Nico Schwartz and Poeko, and funded by the Factum Foundation. The film aims to highlight the fragility of our cultural heritage and the promise photogrammetry holds to preserve it.

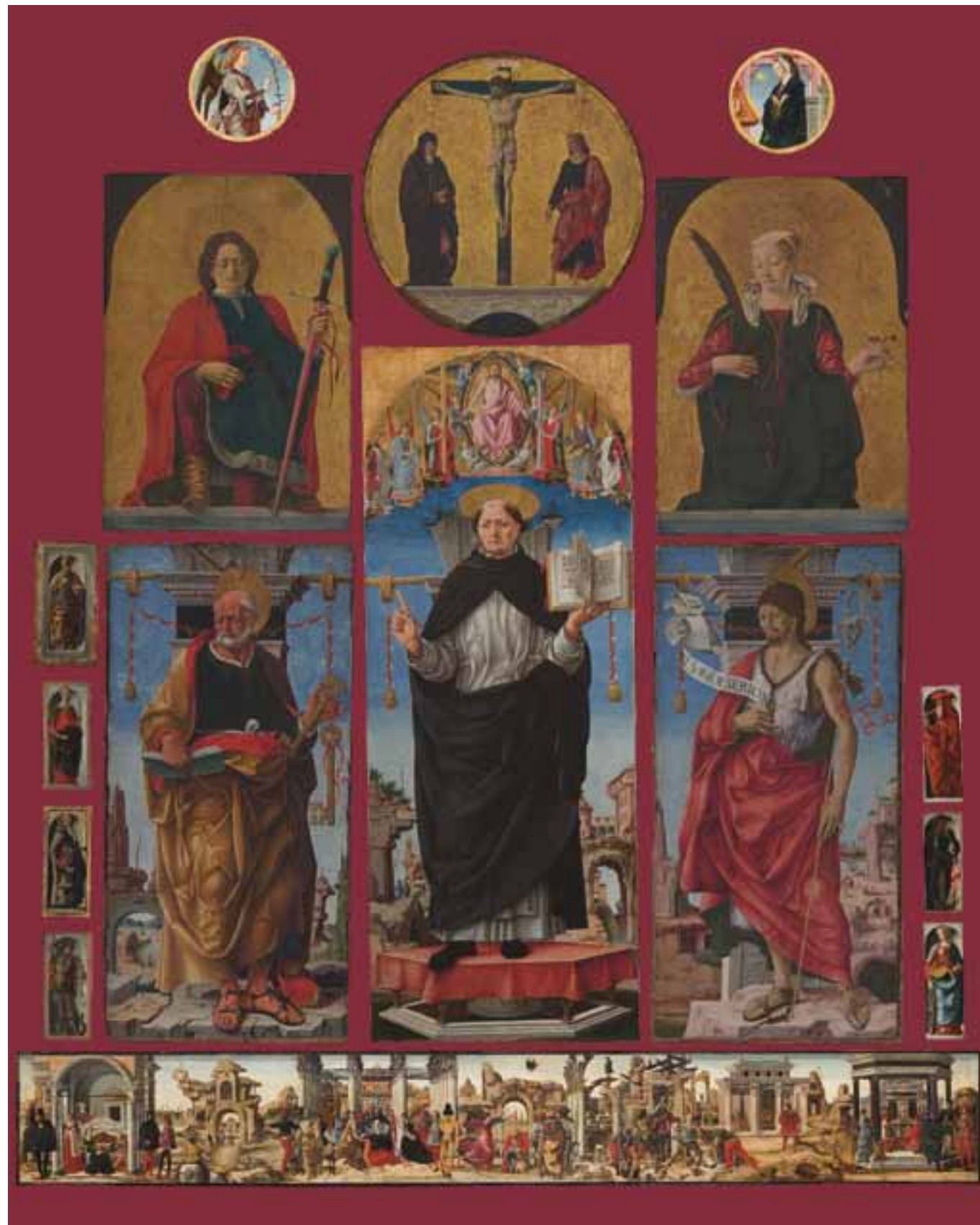

The *Polittico Griffoni* was once the most celebrated altarpiece of the Bolognese Renaissance, painted between 1471 and 1472 by Francesco del Cossa and Ercole de'Roberti. It was commissioned by the Griffoni family for the Chapel of St Vincent in the Basilica of San Petronio. The altarpiece was removed in 1725 when the chapel was patronised by the Aldovrandini family. There are now sixteen known panels of the altarpiece, housed in nine different museums in North America and Europe.

A collaboration between the Factum Foundation and the San Petronio Basilica will result in a high-resolution facsimile of the *Polittico Griffoni*. Over the past 3 years, all the panels have been recorded using the Lucida Scanner and composite-photography. Work is currently underway to make exact facsimiles of each panel in its condition at the time of recording. In an interesting development of the project the two panels in the Brera were recorded before and after restoration.

In order to re-make the subtle relief on the surface of the poplar panels painted in tempera Factum Foundation is working with Océ in Venlo, Holland, using its relief colour printer. At the same time, we are milling the surface into gesso coated wood panels and printing them on the flatbed printer

at Factum Arte. This level of research is critical to understanding how to push the existing technologies and apply them to the creation of accurate facsimiles.

The next phase of the project is to work with experts in Bologna to understand how the altarpiece was originally assembled and how it was framed. When complete, the entire digital archive will be given to each of the participating museums and collections while the finished facsimile will be symbolically 'returned' to the chapel which was 'restored' in an arts and crafts style by Alfonso Rubbiani at the end of the C19th.

This was an organic project, born out of curiosity and opportunity, it has received no external funding. The recording of the panels has taken place in The National Gallery (London), Pinacoteca di Brera (Milan), the National Gallery of Art (Washington DC), Museo di Villa Cagnola (Gazzada), Pinacoteca Vaticana (Vatican City), Museum Boijmans Van Beuningen (Rotterdam), the Musée du Louvre (Paris), Pinacoteca Nazionale (Ferrara) and the Fondazione Giorgio Cini (Venice).

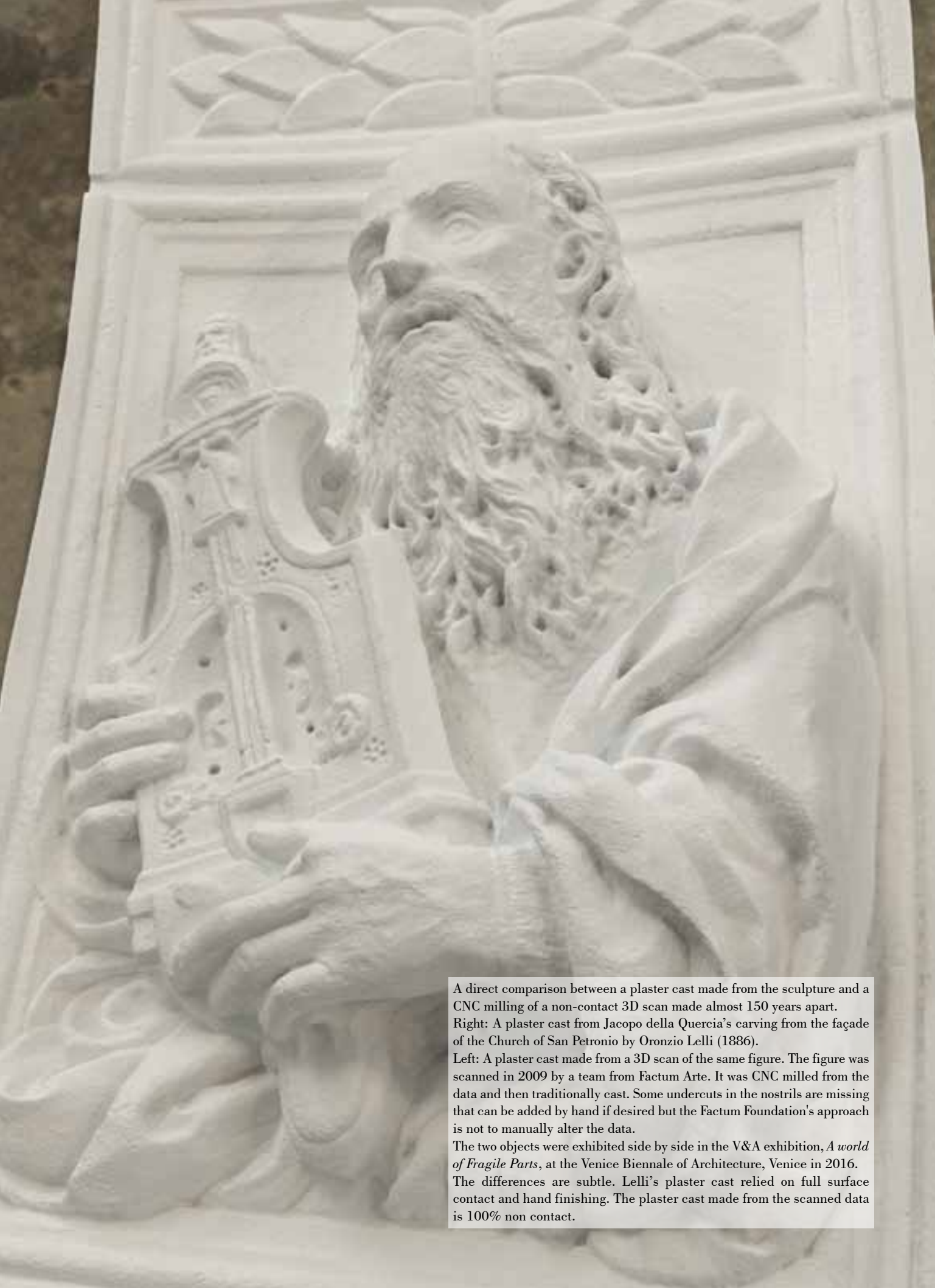

A direct comparison between a plaster cast made from the sculpture and a CNC milling of a non-contact 3D scan made almost 150 years apart.
Right: A plaster cast from Jacopo della Quercia's carving from the façade of the Church of San Petronio by Oronzio Lelli (1886).
Left: A plaster cast made from a 3D scan of the same figure. The figure was scanned in 2009 by a team from Factum Arte. It was CNC milled from the data and then traditionally cast. Some undercuts in the nostrils are missing that can be added by hand if desired but the Factum Foundation's approach is not to manually alter the data.
The two objects were exhibited side by side in the V&A exhibition, *A world of Fragile Parts*, at the Venice Biennale of Architecture, Venice in 2016. The differences are subtle. Lelli's plaster cast relied on full surface contact and hand finishing. The plaster cast made from the scanned data is 100% non contact.





The Teschen Table symbolises the intersection between art, design, politics and the natural sciences in the C18th. It commemorates a largely forgotten, yet highly important treaty in the history of International Relations: The Treaty of Teschen. The Treaty represents one of the defining moments in the evolution of European cooperation, establishing the principle of collective security that underpins many of our international institutions today, from the United Nations to NATO. Created by Johann-Christian Neuber, The Teschen Table was given as a gift by the Duke of Saxony to the French Ambassador, the Baron Louis Auguste de Breteuil in 1780. It is an opulent table covered with 128 semi-precious stones, sourced in Saxony and inset with Meissen porcelain medallions by Johann Eleazer Zeissig; it marks the growing interest in geology in the 1860s and alludes to the

Duchy's mineral wealth and prestige while displaying allegorical celebrations of peace. The table is an extraordinary object that straddles multiple worlds and narratives and defines the interests of the time.

In 2015, the table was sold by the Marquis de Breteuil to the Musée du Louvre. As part of the conditions of sale it was agreed that one facsimile could be made to ensure the table's continued presence in the Chateau de Breteuil. The Marquis contacted the Factum Foundation in the spring of 2015 and requested that the facsimile be produced in the most objective way possible, with the highest level of similarity to the original table in its current state.

A full recording of the table was carried out by Factum Arte in July 2015 at the Musée du Louvre,



Paris. This consisted of 3D scanning with Factum's Lucida 3D Scanner (one of the few systems that can record gold), composite photography, detailed measurements, a recording of the book housed within the table and notes about the condition and surface of the table.

The production of the facsimile took place over the course of several months and was achieved using an array of advanced output technologies including CNC milling, various types of 3D printing, water-jet cutting, multi-layered printing and centrifugal casting. This was done in conjunction with highly-skilled craftsmen who were chasing bronze, cutting stones, electroplating gold and silver, turning wood and bookbinding. The facsimile is an example of what can be achieved when digital and physical artisans work together to produce an uncompromising and articulate object. The facsimile is also informed by research carried out by the Factum Foundation for Digital Technology in Conservation in tandem with external advisers to ensure an objective analysis and attention to detail. Specialists of stones from Saxony, geologists and geological historians, connoisseurs of C18th furniture-making and experts in historical casting techniques were invited to contribute to the project.

The geological samples, semi-precious stones, pearls and porcelain tiles are critical to the look and feel of the table. The stones were reproduced in several different ways: The geological samples were printed in high-resolution on water-jet cut pieces of aluminium coated with gesso.

These were then coated with a crystal-clear resin and polished to give the appearance of stone. A similar approach was used for the decorative stone inserts on the sides and legs. All the inlaid semi-precious stones (quartz, amethyst and agate) were hand-cut in Thailand to 3D files derived from the table. The surface cutting was based on observation while the invisible parts were based on knowledge of C18th stone cutting. The pearls were slotted onto a 3D modelled and printed holders that are inset into a water-jet cut aluminium sub-structure.

One unexpected challenge was to find an appropriate gilding method to achieve the variety of gold tonalities (to reproduce rose, green, yellow and white golds). The table was originally produced using mercury gilding. Most mercury gilding has now been stopped for health and safety reasons and has been replaced with electro-plating. A mix of gold, tin and silver plating was used to create the final surface. The silver/gold mix was oxidised and worked to produce the character of the heavily cleaned and restored top. The gold parts were tinted with 'Corla' - a mix of shellac and pigment to push the tone of the gold towards green or red.



CNC milling the walnut substructure used in the facsimile of the table of Teschen.
Right: A selection of fragments and tests for the facsimile of the table of Teschen.



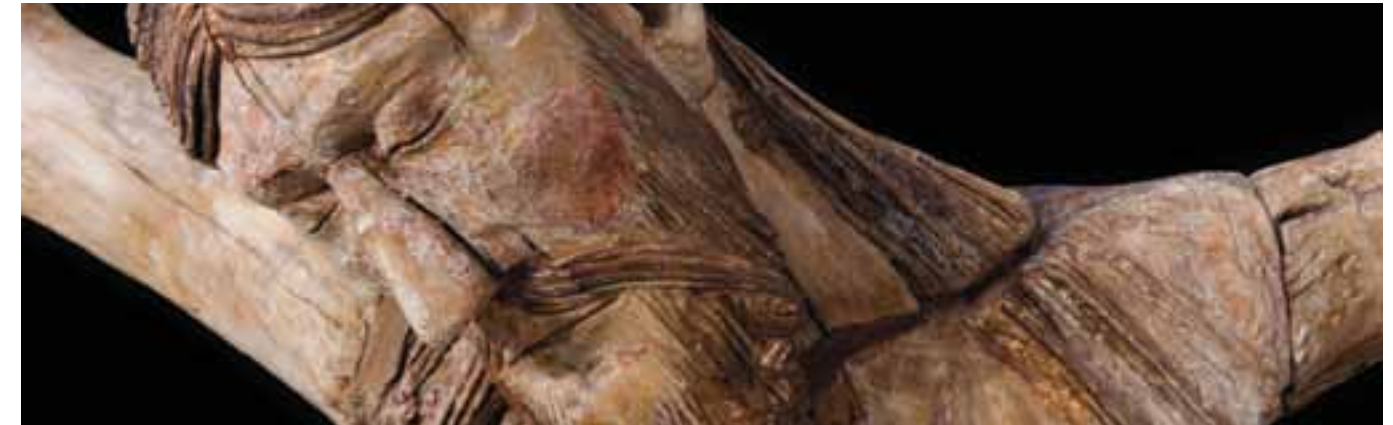

Various stages of the production of the facsimile of a C12th crucifix in the Musée de Cluny made for Rachid Koraïchi.

In April 2015, Factum Arte was asked by Algerian artist Rachid Koraïchi to create an exact facsimile of a polychromatic C12th wooden Christ from the Auvergne in the collection of the Musée de Cluny, Musée National de Moyen Âge in Paris.

This work forms part of Koraïchi's installation *Dialogue avec l'ancêtre* (originally exhibited at Le Petit Palais in 2012) which brought together elements from the three Abrahamic religions in a spirit of tolerance and understanding. The installation is now scheduled to tour to other museums and the Musée de Cluny was unwilling to lend the crucifix for an extended period of time. An exact facsimile was needed with the same feeling and presence as the original.

The production of the facsimile required some innovative applications of 3D output technologies and a deep understanding of the language of conservation in the stabilization of medieval wooden carvings.

The recording work took place over two days in October 2015 using a white-light Breuckmann 3D SmartSCAN. The front and back of the figure were scanned as it was placed horizontally on a table. We were asked by the Musée de Cluny not to create an exact facsimile, so, rather than change the Christ's visible appearance, it was decided the facsimile would be 1 cm bigger than the original.

The files were 3D printed in sections on a laser sintering system (EOSint) in polyamide. At the same time the figure was routed on a 7-axis robot into a block of beech wood. The wooden carving had the shape and feel of the original while the 3D print accurately recorded the surface. This surface data was treated as a skin, cast in a resin designed for the restoration of wooden furniture and laid over the surface of the wood.

The finish was applied by hand. The appearance of the original wood was achieved through a gradual accumulation

of thin washes of colour which were repeatedly knocked back by the application of layers of white. Together these created the complexity and character of the heavily aged surface of the sculpture. The polychrome areas were obtained through an application of synthetic stucco composed of four different layers. This material was made on sheets of plastic and broken to create the reticulated shapes of the painted areas of the original. This process is slow and requires great concentration, a task similar to the work of a conservator on the original object. The final treatment is the application of several layers of natural wax tinted with pigment.

The procedures and techniques that are being worked out during the production of objects like this medieval Christ are evidence of the ways that digital technology and traditional crafts can be fused into a new approach to making that is based on an understanding of the ways in which different materials are mediated and transformed. This approach is opening our eyes to the endless possibilities that can be applied to production of contemporary works of art and facsimiles – in this case it is both a facsimile of a C12th wooden figure and a work of art by Rachid Koraïchi. There are other examples in production in the workshops that blur this division and can make it hard to understand the difference between Factum Arte and the Factum Foundation. This is a Factum Foundation project carried out by Factum Arte to explore the ways that different 3D recording and printing methods can be integrated into the production of long-lasting works of art. Unlike the objects of many other digital producers, longevity is one of Factum's core criteria. This piece was funded by a donation to the Foundation.



Following a small fire at the Church of El Pilar in Mejorado del Campo (the lifetime-work of Justo Gallego) the Factum Foundation devoted the time of a skilled modeller, Juan Carlos Arias to recreate a fire-damaged crucifix at over twice its original size. The burnt remains were 3D scanned, enlarged and routed on a seven axis robot. The surface was then lovingly reconstructed over an extended period of time, gradually finding its new form under the watchful eye of 'Padre' Justo. During a visit to Factum's workshops to inspect the work, Justo was scanned with the Veronica Chorographic Scanner – the result is a face of extraordinary honesty and character.





A 3D rendering of a section of the trunk made using photogrammetry and Capturing Reality software.



The signing Oak in Windsor Great Park being recorded with a Breuckmann 3D SmartSCAN.

The work carried out by the Factum Foundation covers both human and natural heritage. The scanning of an ancient oak in Windsor Great Park is the first stage of an ambitious project to make a 1:1 facsimile of this great living work of art.

These thousand-year-old oaks represent a biological continuity dating back perhaps only seven generations to the last ice age. They are not only of historic interest but are also a valuable part of our cultural heritage.

Ted Green, Conservation consultant at Windsor Great Park and a founding member of the Ancient Tree Forum.

Britain has the largest number of the ancient oaks in northern Europe. Most of them are found in our Medieval Royal Forests such as Windsor Great Park. They are some of the largest and most astonishing living things that can be seen in Britain, but for the great majority they remain unknown. These trees are so ancient that they transcend ideas of national identity. While they might seem uniquely British, they remind us that,

in the lifetime of a tree, what constitutes Britishness is a very changeable thing.

The Factum Foundation, working with Factum Arte, has been pioneering a series of innovative techniques using photography and scanning technologies, 3D printing and centrifugal casting techniques. This application of technology has made it possible to scan a nine-hundred-year-old oak tree, without ever touching it, in order to produce an exact copy; accurate to a millimetre of the tree in leaf. The 3D recording was done using photogrammetry and a Lidar scanning system. The processing has been done using Capturing Reality software and the output is a mixture of 3D laser sintering and CNC milling. The trunk will be cast using the lost wax technique while the leaves and acorns will be cast directly from life. The casting was originally inspired by the work of Wenzel Jamnitzer who in the C16th was casting grasses and leaves in gold and silver.



Early museums were filled both with Culturalia and Naturalia. Factum Arte has been working for several years to perfect the casting of natural forms in metal. In 2015 they collaborated with Michele De Lucchi to make a seven meter tall cast of a 500 year old olive tree and its complete root structure. The result now hangs in the Gallerie Vittore Emilio next to the Duomo in Milan. Wenzel Jamnitzer, the C16th goldsmith from Nuremberg was the master at casting leaves, grasses and animals in precious metals. He was one of the inspirations behind the work to cast trees.



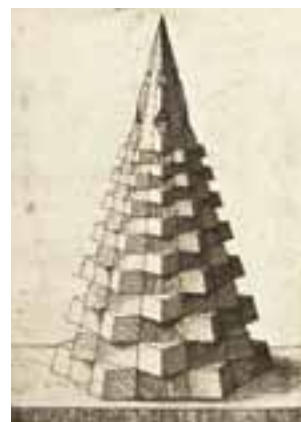
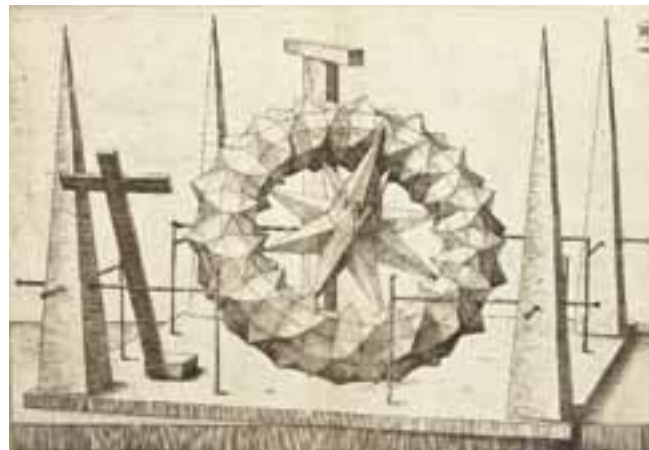
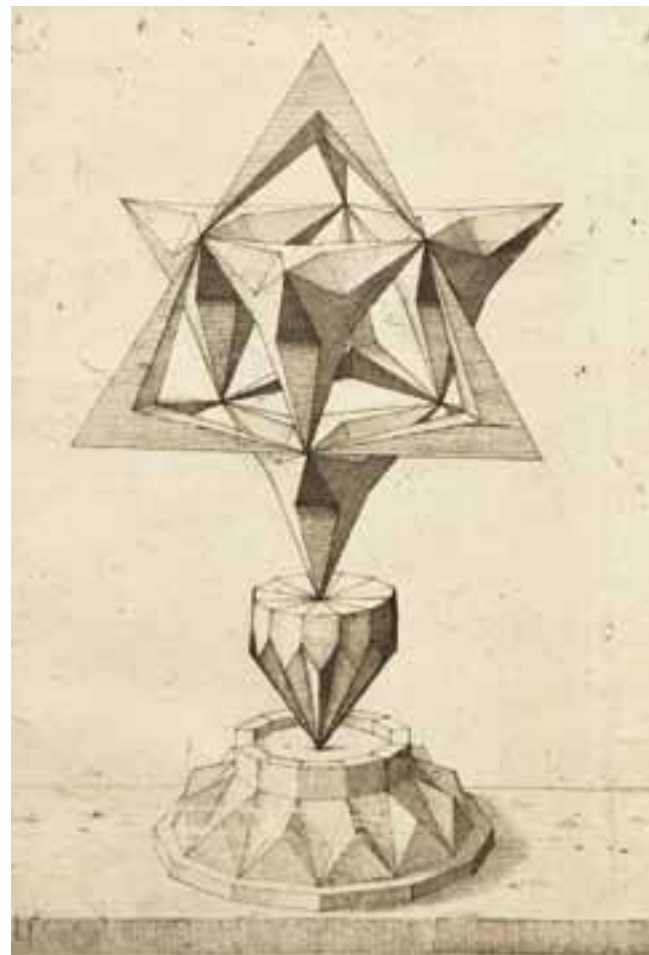

Top: Brass Polyhedra made from folded sheets, based on the design in *Perspective Corporum Regularium*.

Centre: One of the Polyhedral Monuments modelled in 3 dimensions and 3D printed.

Bottom: Paul Pfinzing, *Extract der Geometriae und Perspectivae* (Nuremberg, 1599) was written in German for the craftsmen of Nuremberg. In the copperplates, that illustrate the book in the style of woodcuts, he depicts the systems of Dürer and Jamnitzer. He explains that Dürer's system was used for drawing in perspective but that Jamnitzer's innovations required only a plan and an elevation to conceive complex forms.



Nuremberg in the mid-16th century was coming to terms with the printing press, the materialisation and dissemination of ideas, the transformation and mediation of information and with replicating reality. It was a material world in which a goldsmith had his hands on the most precious matter - and Wenzel Jamnitzer (1507-1585) was its most celebrated artisan. He designed elaborate sculptures for the Holy Roman Emperors, turned animals and plants into gold and produced one of the greatest works of geometry and perspective – *Perspectiva Corporum Regularium* (Perspective of Regular Bodies), published in 1568 - an extraordinary work on art and artifice, ideal form and platonic solids. In this book, Jamnitzer demonstrates that with only a plan and an elevation it is possible to conceive forms of impossible complexity. Effectively, in the mid-16th century, only a few years after Dürer had formalised the principles of representing the world by seeing it as a projection onto a flat plane, Jamnitzer went one step further and effectively invented the language we now know as 3D modelling.

For Jamnitzer, a mirror, a painting, and a mathematical representation are all ways of representing and knowing nature. Nature, and its processes, could come to be known through both imitation and through mathematical representation.

Pamela H. Smith

Despite the fact that he ran a large and thriving workshop, Jamnitzer's reputation has been obscured by the fact that few original works remain. The Factum Foundation is working on an exhibition that aims to provide a new perspective on Jamnitzer's achievements. Using 3D modelling and 3D printing technologies, mixed with precious materials and traditional craft skills, some of his greatest Polyhedral Monuments will be re-made and re-contextualised.

It will be the second exhibition in a series of investigations into the pre-history of digital technologies. The First, *Penelope's Labour – Weaving Words and Images* (Fondazione Giorgio Cini, 2011) focussed on the invention of the Jacquard loom, a system based on punch-cards that was the inspiration of Charles Babbage's 'Difference Engine' – the first computer.

The Jamnitzer exhibition will focus on 3D models made from Jamnitzer's images. It will effectively reverse engineer the process used by Jamnitzer to imagine these complex forms and reveal how his knowledge was embedded in the processes he developed and used.

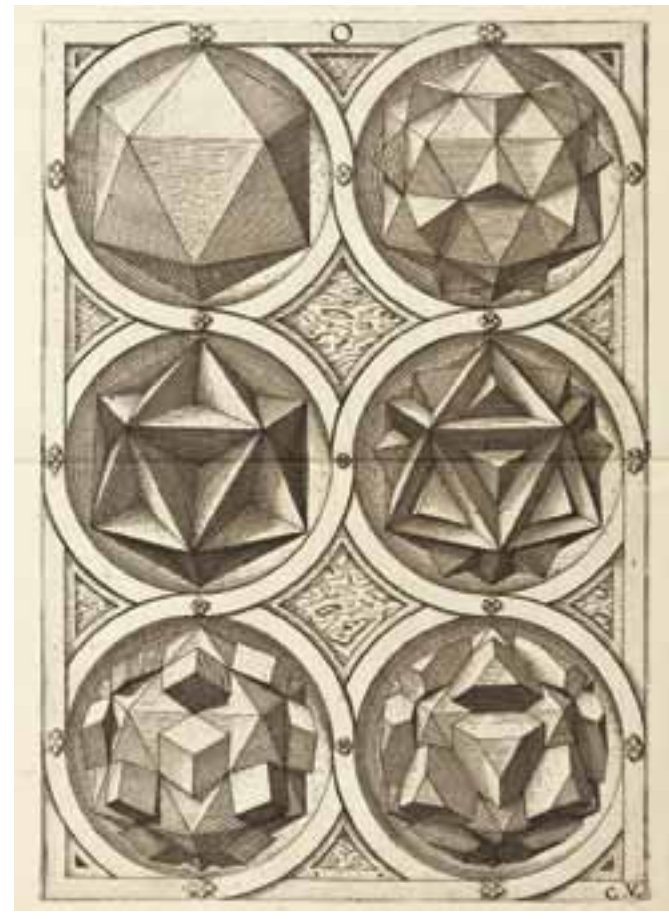
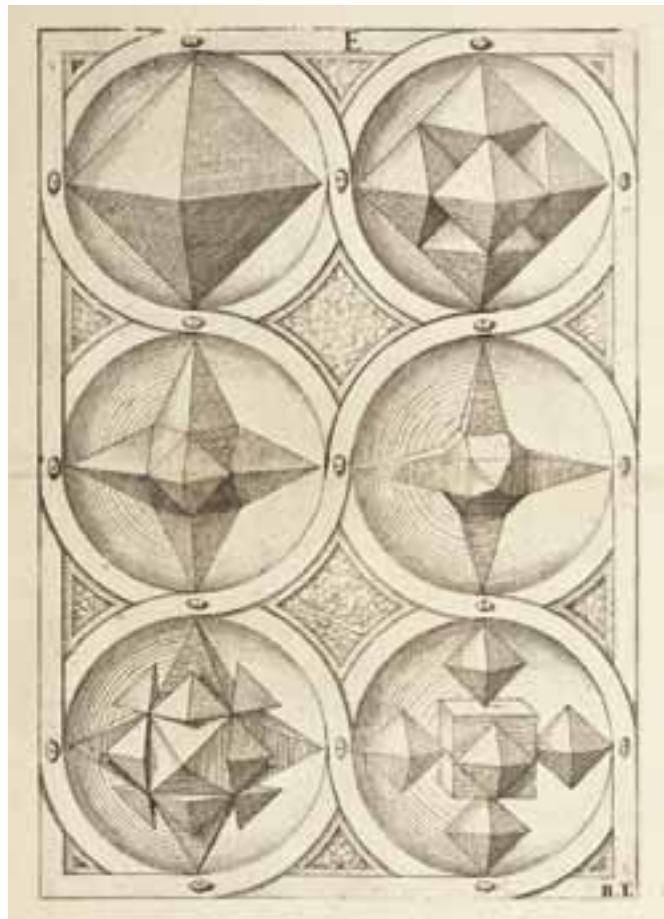
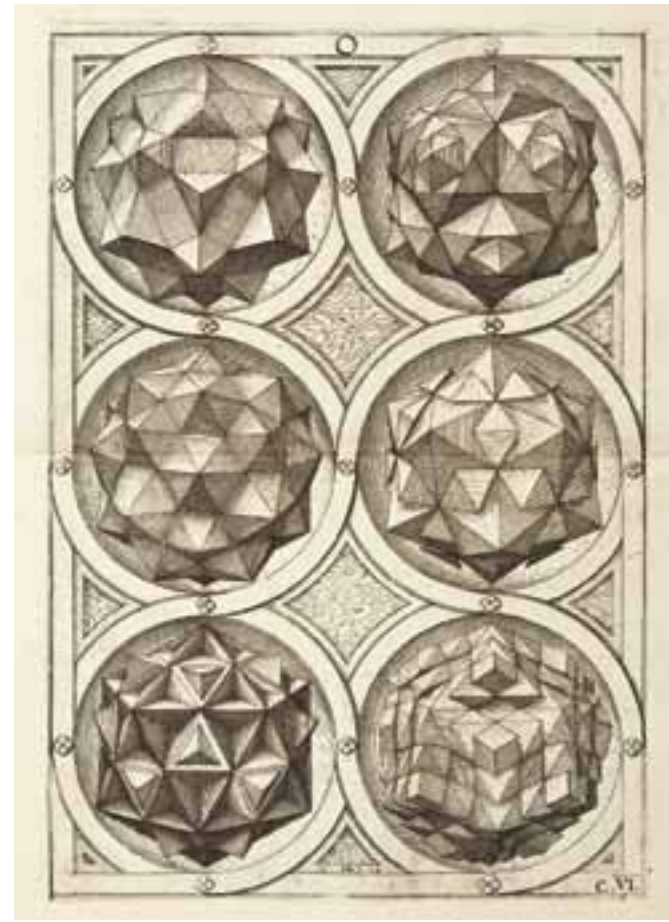
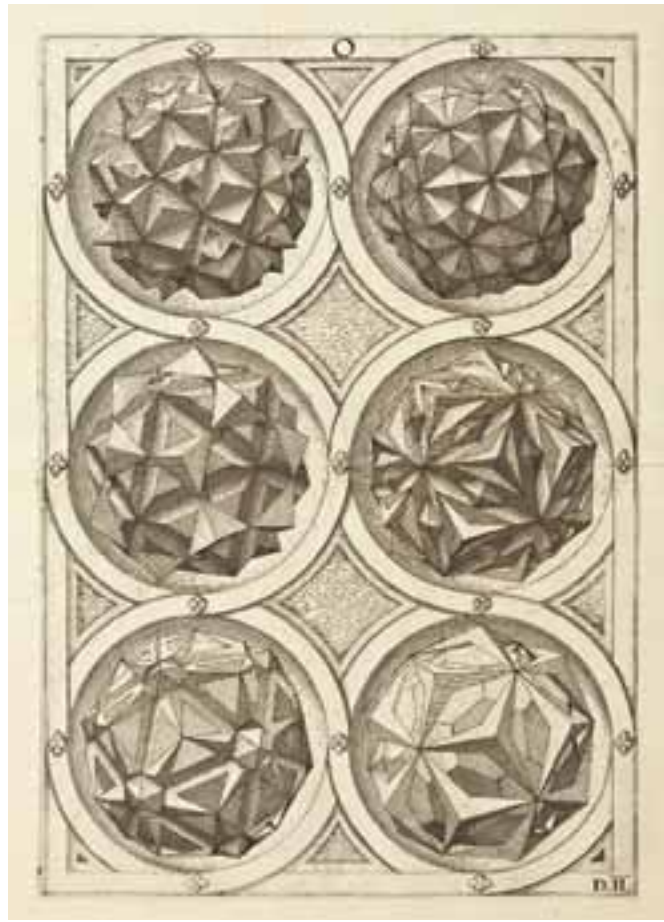

Forms from *Perspectiva Corporum Regularium* (Perspective of Regular Bodies), published in 1568, realised as 3D models printed using laser sintering.

Left: A page from *Perspectiva Corporum Regularium* (Perspective of Regular Bodies), published in 1568.



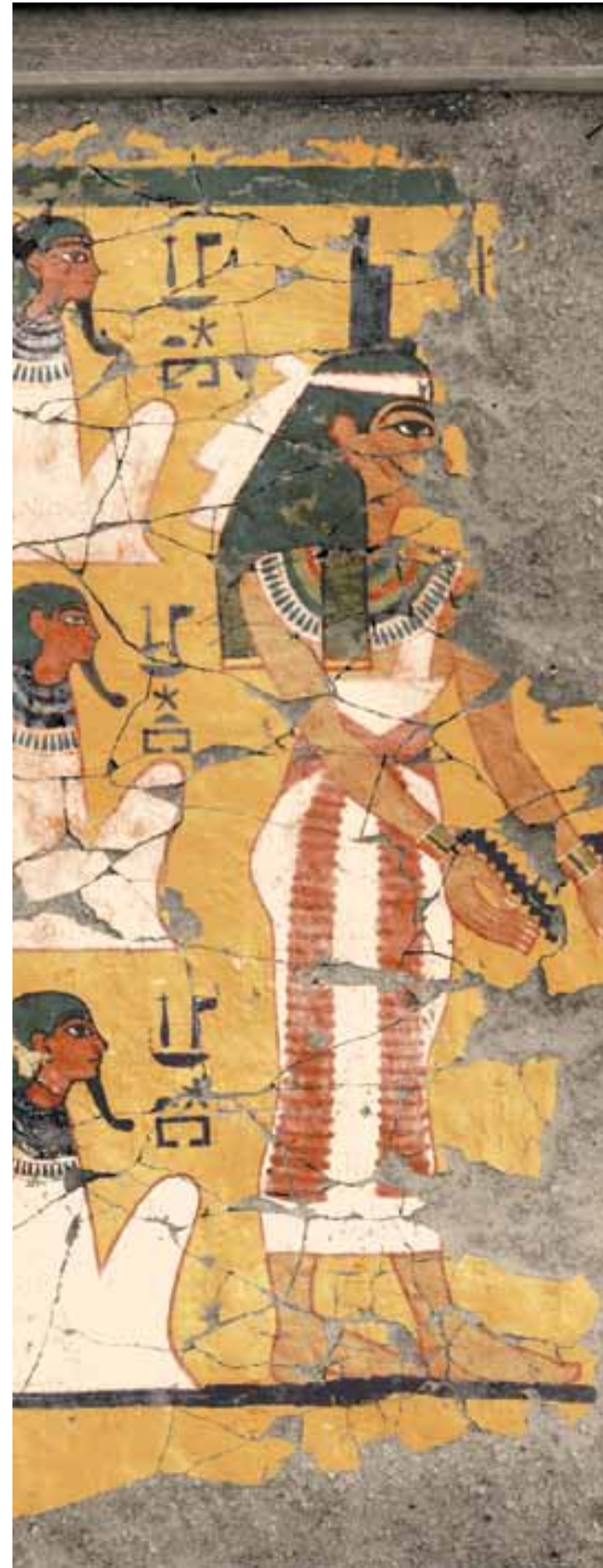

Digital restoration is emerging as an important new area that is dependent on the quality of the different types of recording to create virtual models that reveal different points of view or theoretical ideas. Digital restoration refers to restoration projects carried out on digital archives. An important advantage of digital technology is the potential to manipulate the data in a virtual space without touching the original. It is possible to digitally restore the object both by working with specialists to modify the data and by scanning fragments that have been dispersed in museums and private collections worldwide. In this way the data can be merged to produce a digitally restored facsimile of a damaged or dispersed original. The precise protocol for this is being established and new developments are being incorporated. The Foundation is encouraging an approach that will result in more and more emphasis on virtual restorations and a greater period of time for reflection before interfering in the physical domain.

Given changing attitudes and ideologies in conservation practice it is essential that works of art are fully documented and that ideas are tried out in a virtual space before any restoration treatments are undertaken. If this is done there is always a record of how the work looked before restoration.

One of the most important tools that has been developed by the Factum Foundation is a browser that facilitates the viewing of high resolution data as layered, aligned images on the internet in a secure form. Having all the data together at the same scale is important, but simultaneously being able to separate the surface from the colour, or compare the evidence of damage on the surface with an X ray or an infra red image, will change our understanding of many works of art. It is also our policy to incorporate historical records whenever possible. Sometimes these can be remarkable examples of old technologies but normally they are scanty and incomplete.

Digital Restoration: Tutankhamun and Seti I

During the Tutankhamun project, working with assistance from the Griffith Institute in Oxford who supplied a high resolution file of Harry Burton's photograph of a fragment removed from the south wall of the tomb of Tutankhamun, Factum Arte were able to reconstruct the south wall's missing fragment for the Foundation (see opposite). All colour information was based on the high-resolution recordings made in the tomb. This missing fragment is now on display in the facsimile in the Valley of the Kings. It helps to explain to the visitor that they view the burial chamber through an opening made in the C20th.

Working with the Griffith Institute we have also carried out a test scan on one of the 'paper squeezes' in their archive (see above). It was common practice to make casts of the relief carvings in the tomb of Seti I using wax, plaster and paper molds. Each process has a disastrous effect on the condition of the tomb. By recording and including the collection of squeezes in the Griffith institute in the facsimile we will be able to explain why certain areas are in much worse condition than others.

In the facsimile of the tomb of Seti I, digital restoration will take on a physical form. The aim is to 3D scan all the fragments removed from the tomb that are now in Museums and private collections around the world. Working with Erik Hornung, the world expert on the tomb, it will be possible to return them to their original location. Once these are re-integrated the integrity of the tomb and its text will be partially restored. It will also be possible to work with different experts to suggest how the tomb may have looked when it was uncovered in 1817, or how it may have looked in the days of Seti I. Speculative interpretations are better done away from the original. Many 'original' works have been turned into reproductions of themselves through insensitive or heavy-handed restorations.



A 3D scan of a crudely restored section of the tapestry.



The facsimile hanging in the stove room of the Museo Cerralbo.

In 2015, the Factum Foundation recorded and digitally restored a tapestry in the Museo Cerralbo in Madrid. The tapestry was from the C18th, located in the stove room, and made from wool and silk, featuring a decoration of plants, flowers and birds. The Factum Foundation was commissioned by the Instituto del Patrimonio Cultural de España to make a facsimile that would hang in tapestry's original location allowing the original to be properly protected and stored to prevent further damage.

The recording of the tapestry was done in collaboration with a conservation team from the Real Fábrica de Tapices. Surface data was recorded using the Foundation's Lucida laser scanner, while colour information was recorded using a Dr. Clauss Panoramic Photographic system. The resolution of the data, the recording of the tapestry both front and

back and conversations with tapestry historians and conservators allowed the digital restoration team at Factum to determine its original colours and tonal range at the time of its production in the C18th. The digital restoration concentrated on restoring damage, replacing poor quality repairs, removing stains and re-colouring areas that were significantly faded. The digitally-restored file was then printed onto an Ottoman fabric with a similar texture to the original. The result is a physical facsimile that is remarkably similar. This work has already resulted in a one-day workshop and conference at the Instituto del Patrimonio Cultural de España and a detailed report in Spanish and English that explains the process in detail.



From top left to bottom right: A series of images showing all the stages of digital restoration.





San Baudelio de Berlanga is an 11th century hermitage in Soria, North Eastern Spain. It was constructed and used as a church by the Mozarab community. The Mozarabs were the Arabic-speaking Christian community that thrived in Spain over the centuries of Muslim rule. Soria, in particular, has a powerful history of Muslim, Christian and Jewish cohabitation and tolerance.

The interior of San Baudelio is covered with frescoes displaying overtly religious scenes like the Last Supper, to other depictions that are harder to identify such as an elephant with a castle on its back, a warrior and detailed hunting scenes. In 1922, many of these paintings were removed by the 'strappato' technique, an aggressive detachment procedure. The paintings were then restored in London, shipped to New York, and eventually sold. Some were returned to the Prado in 1957 by the Metropolitan Museum.

In 2013, The Factum Foundation started a project to virtually restore the wall paintings of the hermitage. High-definition photographs of the walls were taken and a detailed reconstruction of the heavily damaged wall paintings began. The aim is now to record all 23 fragments in the US and in Europe, and to digitally reunite them (24 fragments were removed but the whereabouts of one is unknown).

Adam Lowe and Carlos Bayod will be running a course on Advanced Preservation Technology at Columbia University in New York during the autumn of 2016. This course will mix theory and practice and one module will focus on the recording and the digital restoration of the panels in the Cloisters and other collections in the US (assuming permissions are granted).



Recording in the Sala Bologna. The badly damaged landscape of the Province of Bologna can be partially seen on the right hand wall.

In April 2011, The Factum Foundation began to digitally restore a fresco of a bird's eye map of the countryside surrounding the city of Bologna, located in the Sala Bologna in the private quarters of the Apostolic Palace, in the Vatican City. It is immediately outside the Pope's private chambers, in an area that is inaccessible to the public. The fresco was commissioned by Pope Gregory XIII in 1575 and painted by Lorenzo Sabatini. The digital restoration was carried out in collaboration with Dr. Nadja Aksamija and Francesco Ceccarelli, lecturer at the University of Bologna. Working with his students, he supplied many supporting documents, such as maps and drawings from the period. These were used to interpret some of the most damaged areas of the map and to reconstruct many of the toponyms that had become illegible.

The digital restoration was conducted in several steps. First, cracks that covered the surface of the map were retouched. Second, a careful and painstaking reconstruction of the towns and buildings representing cities and villages was conducted. In this second phase, attention was paid to

accurately match colour and form. Old and modern maps were used to find the right locations for several areas and points of interest that have now disappeared. Within the area of the city of Bologna itself, the restorer Anna Paola Ferrara, noticed a rather obvious piece of damage. After carefully checking, she was able to show that the area coincided exactly with the location of the Basilica of San Petronio (see opposite). She re-introduced the church using the same drawing style but highlighted the additional material using a slightly different chromatic scheme, a standard protocol in restoration. The final stage was the careful and difficult restoration of the countryside including details of fields, streams, rivers, water works, hills and contours. The digital restoration was recently completed and supplied to the Vatican and the Museo della Citta in Bologna where a facsimile of the largest map of the Renaissance, also from the Sala Bologna, was installed by Factum Arte in 2011.

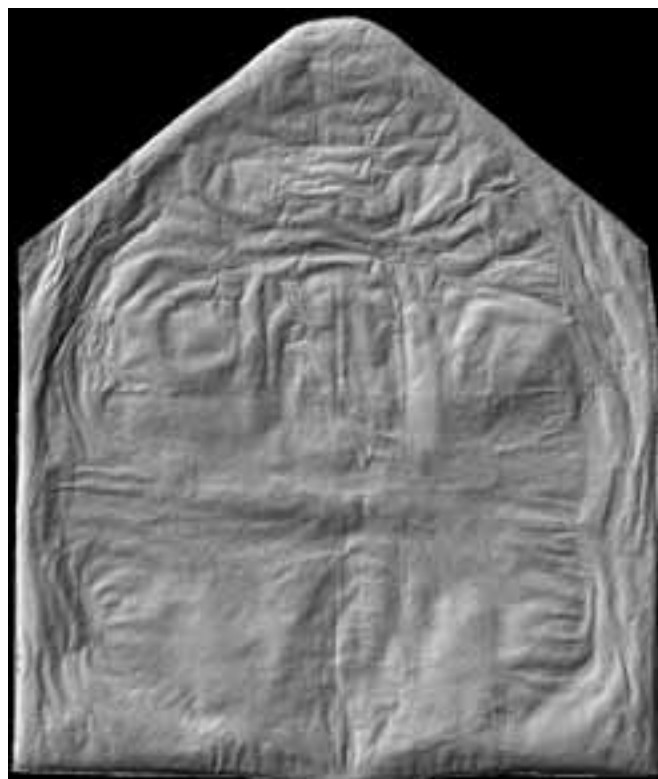

In January 2016, three years after the scanning of the Mappa Mundi (in order to create a tactile display that has been exhibited next to the original map for the blind and partially sighted), a team from Factum Arte, supported by the Factum Foundation, returned to the Hereford Cathedral to carry out the second part of this unique documentation project: recording the colour of the map and scanning the surface of the backboard on which it may have been drawn. If we can prove that there is a direct link between the map and the backboard we will hopefully be able to call a conference of medieval and cartographic scholars to discuss where and when the map was made. The colour of the Mappa Mundi was recorded using composite photography, a process that involves taking hundreds of high-resolution macro photos. These individual shots are stitched together and lens distortions are corrected to produce a single gigapixel image of the Mappa Mundi in its current state of conservation. The 3D scanning the surface of the backboard was done using the Lucida 3D Scanner, a system has been evolving since it was first used to record the Mappa Mundi: the overall structure supporting the scanning head is more precise and robust and the software's user interface is more intuitive and easy-to-use. The flat surface of the backboard was recorded with the Lucida, while the carved border and edges were recorded using photogrammetry.

The scan of the backboard (see following page) will hopefully establish a direct relationship between the 'features' on the Mappa Mundi and those on the oak boards. There is clear evidence of the compass point in the centre

of Jerusalem, the centre of the map. If other points, like the centre of the labyrinth at Knossos in Crete can also be registered it could indicate that the mappa and the backboard belong together. Dendrochronology tests have indicated that the wood from which the backboard is made was from trees that grew in the Hereford area and were cut in 1295 AD. As part of this research, the 3D and colour data of the map and the 3D data of the backboard will be registered together as a multi-layer digital file; an intuitive way of reading these objects without the need to have access to the original. This information will be re-materialised to create a 1:1 scale, high-resolution facsimile of the Mappa Mundi that will belong to the Cathedral and which could be made available for exhibitions that reveal the importance of the Mappa Mundi. As the most recent outcomes in the Tutankhamun project have made clear, a great deal of new information can emerge by documenting and inspecting the relief and texture of cultural artifacts. Navigating high-resolution 3D renders of a surface, without the colour, opens possibilities into the understanding and dissemination of cultural objects.

This project, like many of the cartographic initiatives undertaken by the Foundation, was carried out with the cartographic historian Jerry Brotton, professor of Renaissance Studies at Queen Mary's London University.

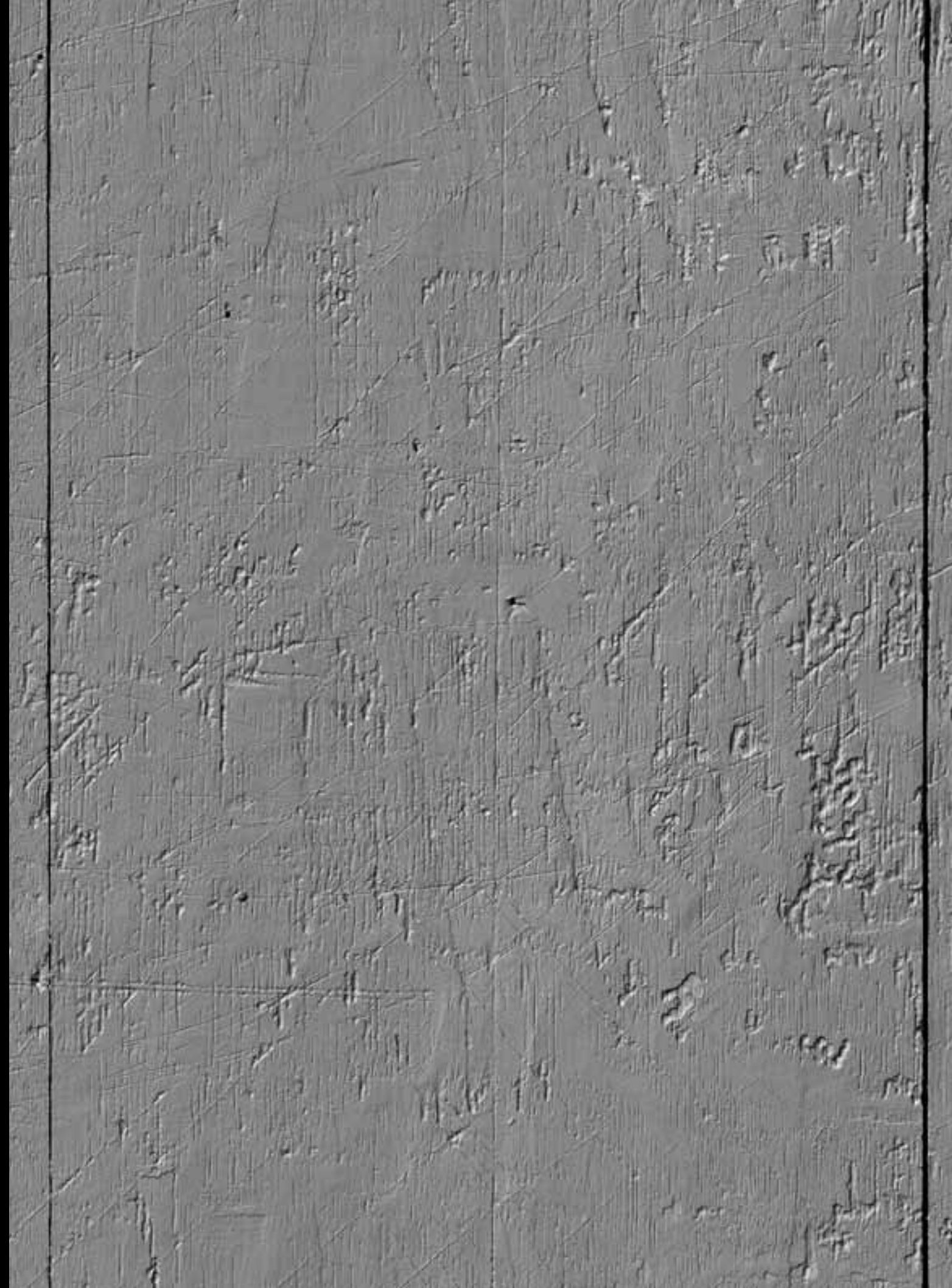
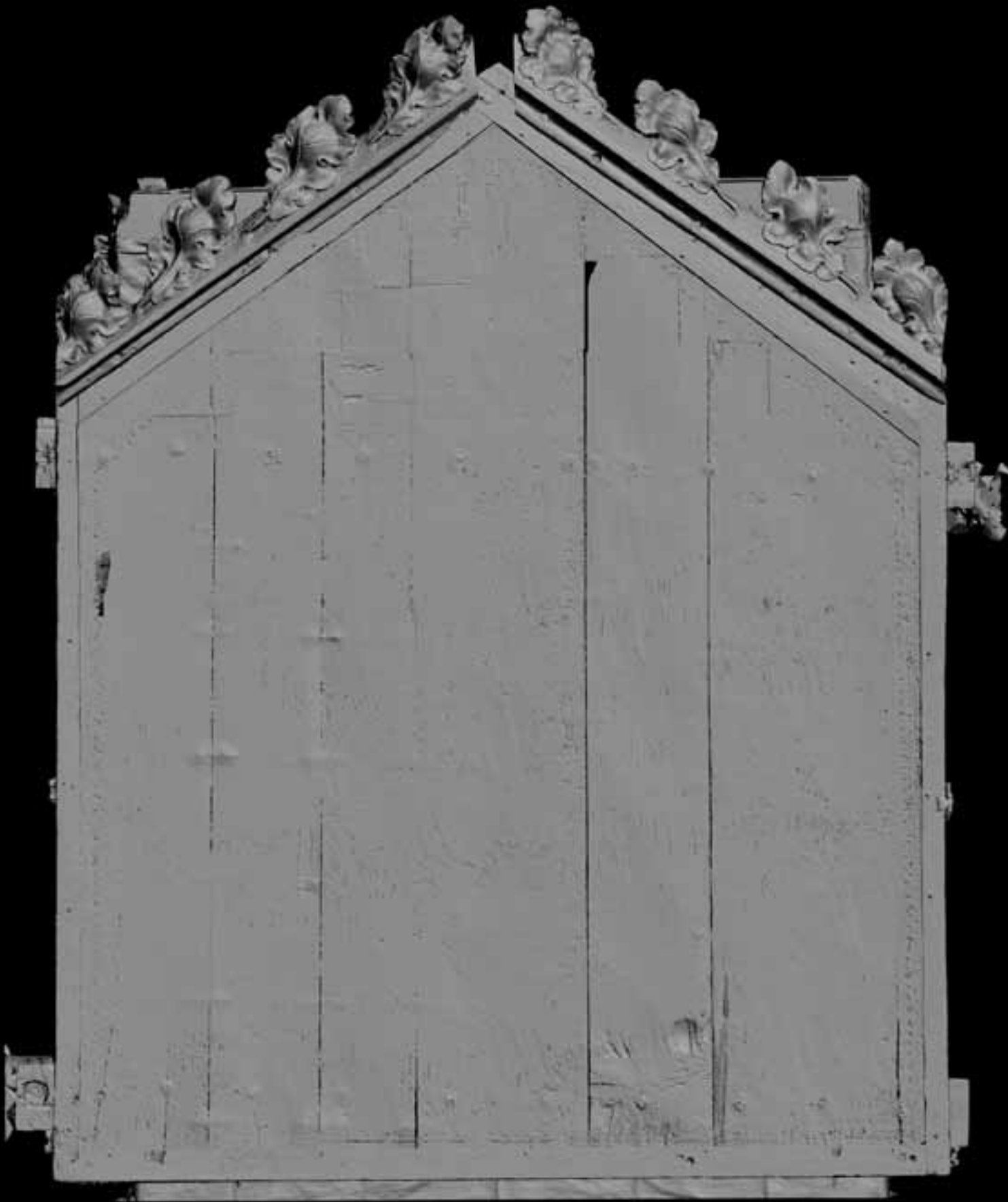

A 3D scan of the backboard and a detail of the centre of the backboard. The deep pinprick in the centre of the image corresponds to Jerusalem. If we can find other points of correspondence between two dynamic materials (vellum and wood) there may be sufficient evidence to show that the backboard and the map belong together.

**Gough Map & Selden Map at the Bodleian, London
Borsano Map at the Biblioteca Nacional, Madrid**

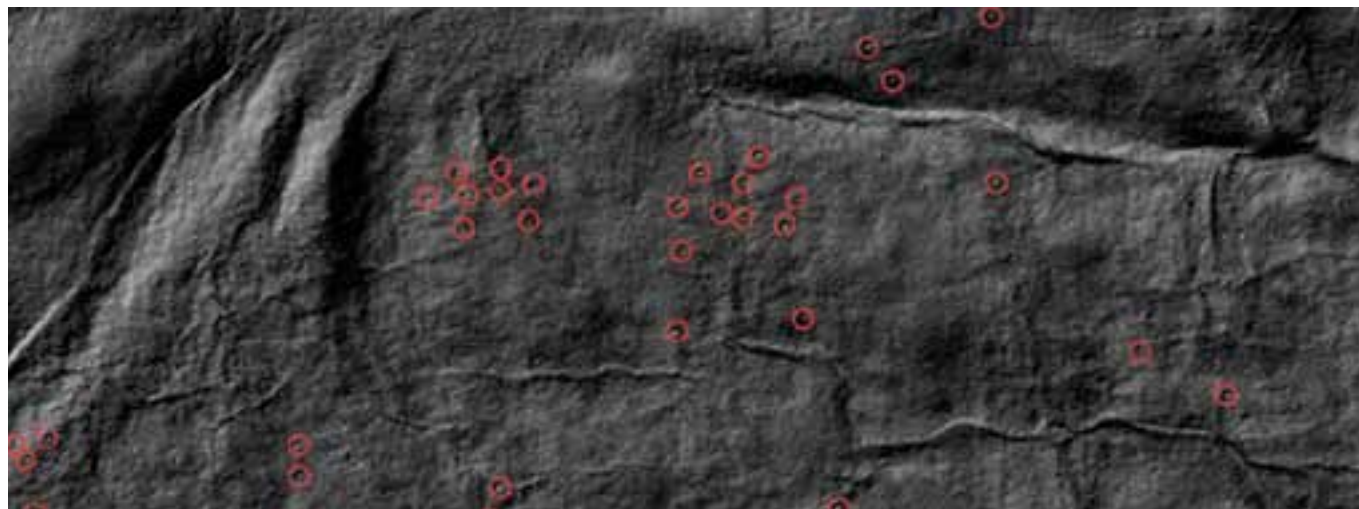
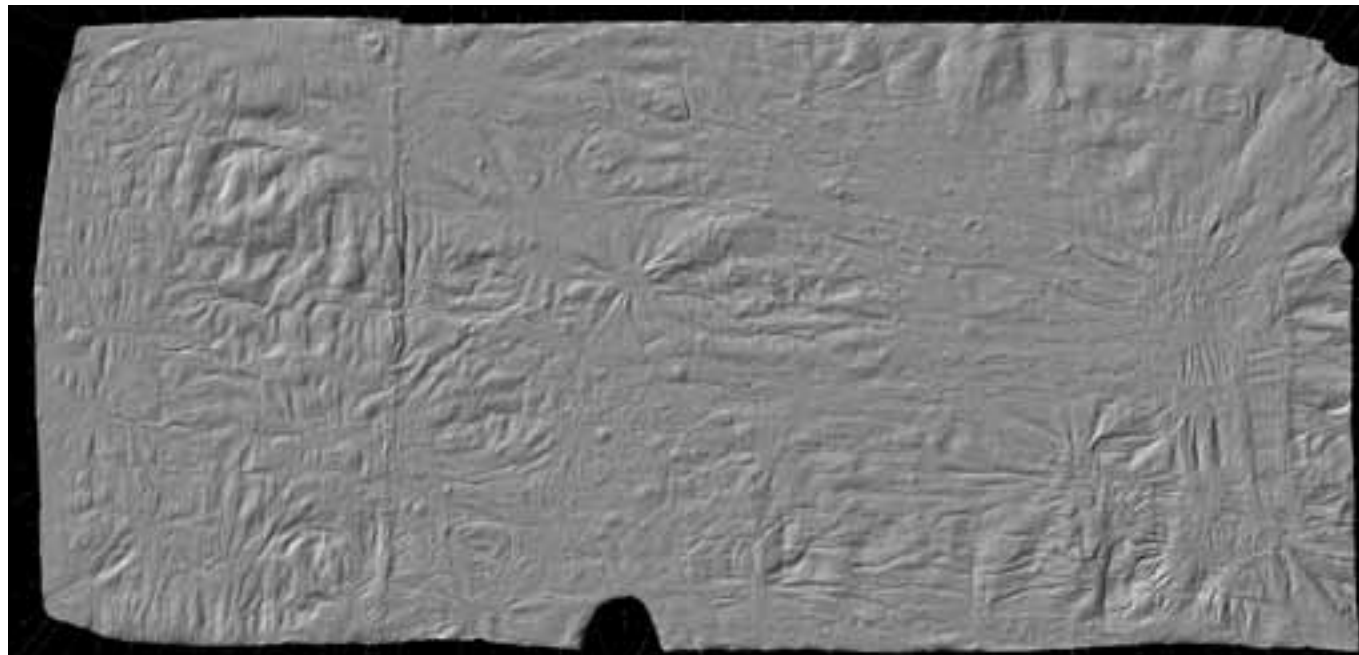

In December 2015 Factum Arte completed the digitisation of the Borsano Map at the Biblioteca Nacional de España. The manuscript map of Catalonia by Ambrosio Borsano, a large work dedicated to King Carlos II, is held in the Department of Fine Arts and Cartography of the BNE. Dated 1687, it is the oldest known large-scale representation of the Principality of Catalonia. The high-resolution colour digitisation of the map has been carried out with the Clauss panoramic composite photography system. The final image, resulting from the stitching of more than 500 shots, has been used to substitute the current image at the BNE's virtual gallery (Biblioteca Digital Hispánica), which is now accessible online. The captured data could be eventually used for creating a physical facsimile of the map.

The Gough Map, at the Bodleian Library in Oxford, is renowned internationally as one of the earliest maps to show Britain in a geographically recognizable form. Questions still remain of how the map was made, who made it, when and why. The Factum Foundation is currently involved in a new initiative involving the Bodleian Library in Oxford and Queen Mary University to scan this precious map. The Gough map is a mid-14th century map of the British Isles, regarded as the oldest route map of the country. Its dating, authorship and function are unknown and the scanning process hopes to shed light on these and many other aspects of its creation. The Factum Foundation is committed to demonstrating the importance of digital technology in the analysis and documentation of our cultural heritage. Non-contact, high-resolution 3D scanning will provide valuable data of the subtle relief of the map, which can then be combined with other layers of information such as colour in order to monitor its condition and understand its biography. The Factum Foundation also scanned the Selden Map of China with the

Lucida 3D Scanner. The Map is another one of the Library's most important but enigmatic maps. Only recently rediscovered, it is also anonymous and dated to the early C17th. It is believed to have been made by a Chinese map maker as it shows Southeast Asia and its maritime sea routes. Factum Arte and the Factum Foundation, working with the Bodleian's Map and Conservation departments as well as in collaboration with other companies, hopes that it may unearth the secrets of two of the history of cartography's most prized maps. Comparing 3D data from Lucida with multispectral recording of the Gough Map, Damien Bove said: "(...) I'm finally getting around to adding my own marks to yours - to identify both the pinholes and the other features that have left a 3D trace. (...) From all this you can see that your scan has done pretty well - showing a few things we couldn't see before and supporting a few of our assumptions."

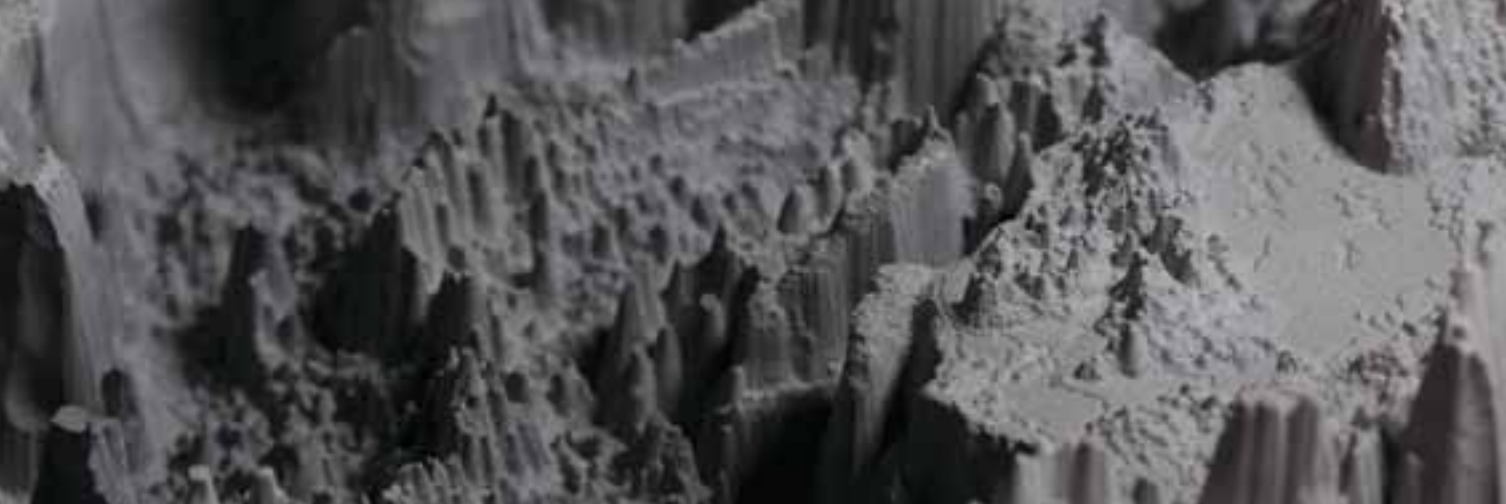

Terraforming – engineering the sublime is an on-going collaboration between Adam Lowe and Jerry Brotton to use the ‘reality’ of cartographic representations to draw attention to the dynamic relationship between climate change and the materiality of the surface of the planet. It was originally conceived as an installation the size of a football pitch on the island of San Giorgio Maggiore in Venice to celebrate the start of the Anthropocene Epoch. It is currently undergoing some changes and may appear in Dubai or elsewhere.



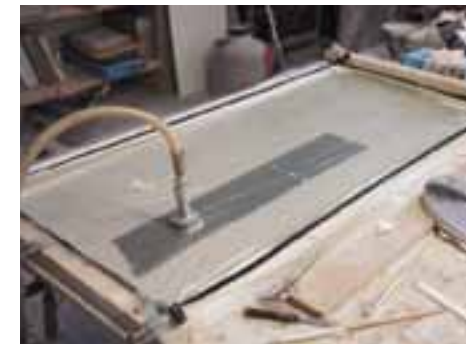
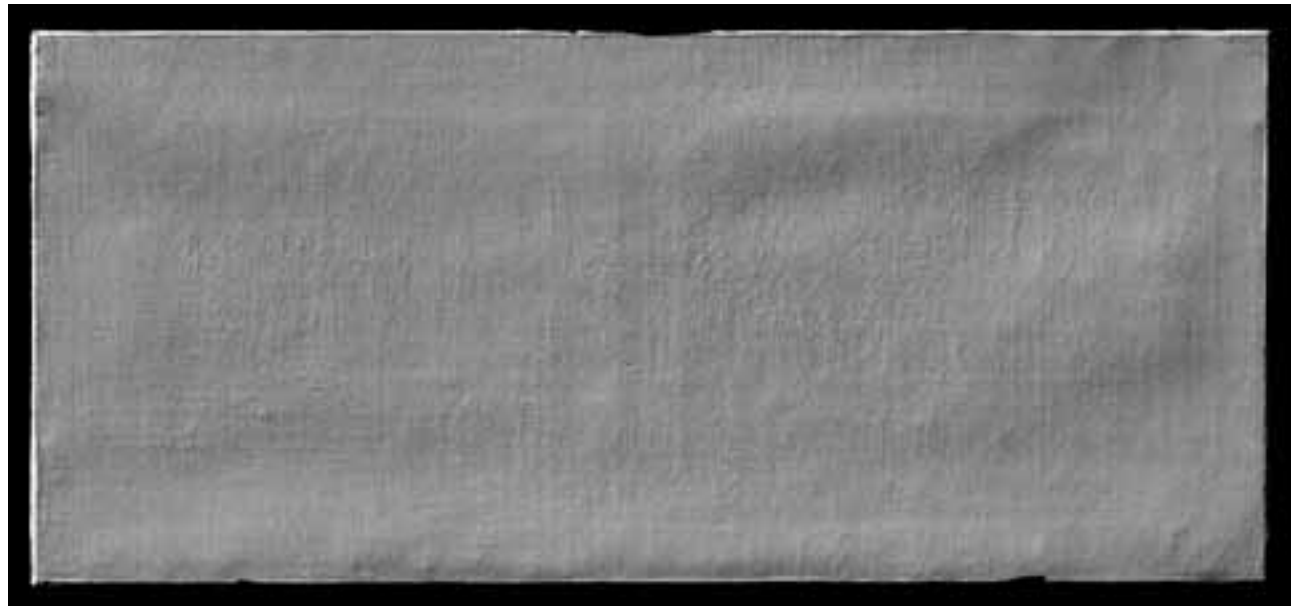

The Factum Foundation produced a facsimile of a painting of the Marriage of Henry VII that originally hung on the staircase in Strawberry Hill before it was removed and sold to the Royal Collection. The painting was recorded at Hampton Court Palace in 2013 and the facsimile installed in the restored Strawberry Hill House in 2014. This was the start of a project to return many of the missing works in the form of exact facsimiles.

The next work to be 'returned' to the restored Strawberry Hill House will be the portrait of Sir Robert and Lady Walpole by John Giles Eccardt in an elaborate carved frame that has been rather optimistically attributed to Grinling Gibbons. The painting and frame were recorded at the Lewis Walpole Library in Farmington, Connecticut (part of Yale University) in 2015. The work involved the use of digital technologies combined with traditional craft skills including photogrammetry, laser scanning, laser sintering, CNC

milling, flatbed multi-layered pigment printing, painting, varnishing, gilding and lettering. It will be unveiled in July 2016.

This will be followed by the recording of George Vertue's copies of Hobein's portraits made using an oiled paper that now hang in Sudeley Castle and Allan Ramsay's portrait of Mrs Laura Keppel and Charlotte Lady Huntingtower (Museum of Fine Arts Boston). Further works by Luca de Heere, Van Dyck, Reynolds and others will be scanned during the next 12 months and installed into the house as they are finished.

The creation of the Eccardt replica and frame was funded with a generous donation from The Murray Family and the Friends of Strawberry Hill. The collaboration between Strawberry Hill House and the Factum Foundation is an example of what can be achieved when new technology is used in a sensitive way.





The majority of images we have of the Cochno Stone originate from the 1937 visit of the archaeologist Ludovic Maclellan Mann, who strikingly painted in the markings to illustrate his 'archaeo-astronomical' theories of their meaning. There is no consensus among experts as to what they actually mean.



The Cochno Stone project is a collaboration between The Factum Foundation, the University of Glasgow Archaeology Department, Richard Salmon Restoration and Elemental Films. The aim of the project is to excavate, 3D scan, safely rebury and produce a facsimile of the Cochno Stone: Scotland's finest example of a Neolithic cup-and-ring marked stone that was buried in 1964 to protect it from vandalism. When finished the facsimile will be installed close to where the original is buried. Factum Foundation and the University of Glasgow Archaeology Department will be working closely with Historic Scotland and West Dunbartonshire Council to establish safe excavation, conservation and reburial methods. A test excavation in 2015 led to Historic Scotland and West Dunbartonshire Council granting permission for The Factum Foundation to search for funding. Through a positive example of Match finding the excavation and recording of the Cochno Stone will take place in the summer of 2016.

The test excavation deepened Factum Foundation's understanding of the Cochno Stone in relationship to its

social context. Over the three days of the excavation a large number of locals, from primary school children to older people with childhood memories of the Cochno Stone, came to visit the revealed section. The intensity of feeling was extremely poignant, with excitement for the proposal and sadness that the stone had been buried through the council's lack of trust of the local people. Intriguing recollections came to light: Mann's markings (that Factum assumed were all white from the photographic records) in fact included red and blue with green used to highlight the strange four-toed feet marks. The Factum Foundation is currently considering the best method of communicating the visual impact of the stone; one idea is to produce the facsimile with Mann's markings from a combination of local memories and existing photographs.



Technology is sold as something slick, designed and clean. The table where the Lucida scanners are assembled often looks like a mess. Except for the cameras every element of the Lucida scanner (both hardware and software) has been made in house.



Lucida 3D Scanner.



A Lucida Scanner that has been modified to work horizontally to record the pages of a book.

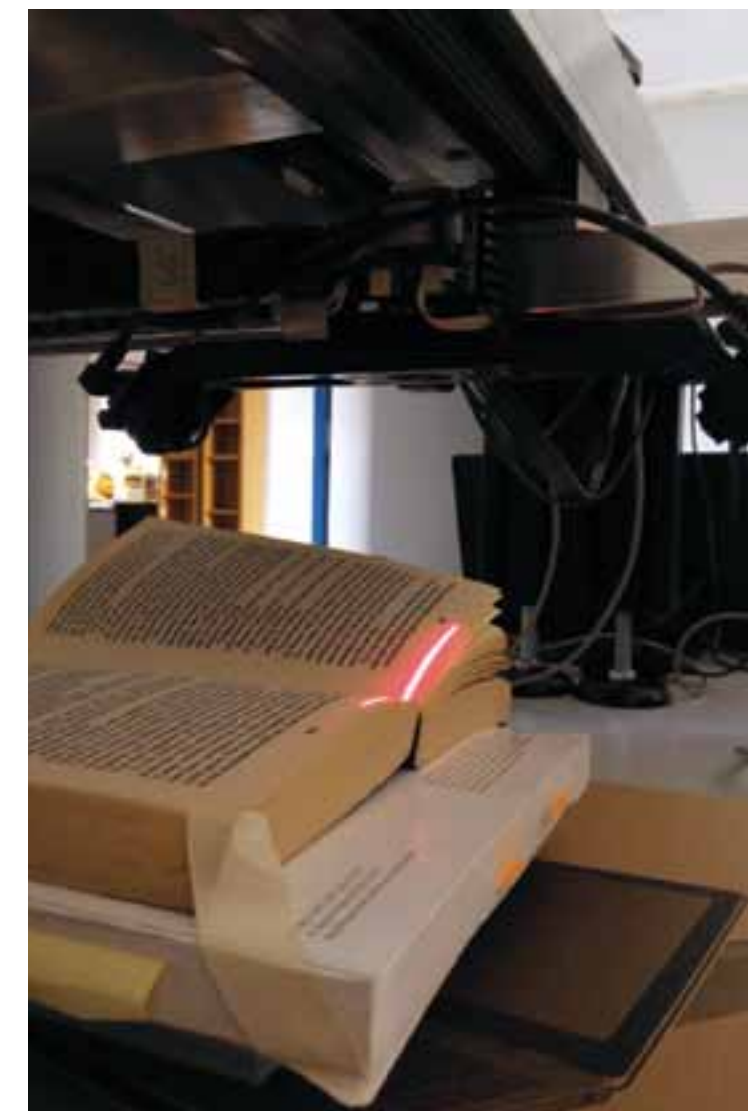

The Lucida is a 3D laser scanner custom built by Factum Arte with financial and logistical support from the Factum Foundation. Conceived and developed by artist and engineer Manuel Franquelo, it is the result of fourteen years of research into the high-resolution recording of the surface of paintings and relief of objects. The constant improvements to both the hardware and software have resulted in a lightweight, robust and reliable scanner that can accurately record surfaces producing a close correspondence between the digital file and the original surface – the challenge is always to ensure that the noise/information ratio is weighted in favour of information.

There is now a working scanner in the National Gallery in London that has been used to record a painting by Bellini

before and during restoration (and soon to be used again to record the surface after restoration). Three Lucida scanners are at work in Luxor and two more will be sent as soon as the restoration work in Stoppelaere house is finished. One scanner as at work in Daghestan and others are moving around Europe. The scanner has also been used in North America. It will be used in Columbia University in New York during the course on Advanced Preservation Technology in the autumn of 2016. The most recent recording was at the Biblioteque Nationale de France in Bordeaux where a horizontally mounted Lucida was used to record a letterpress printed book.

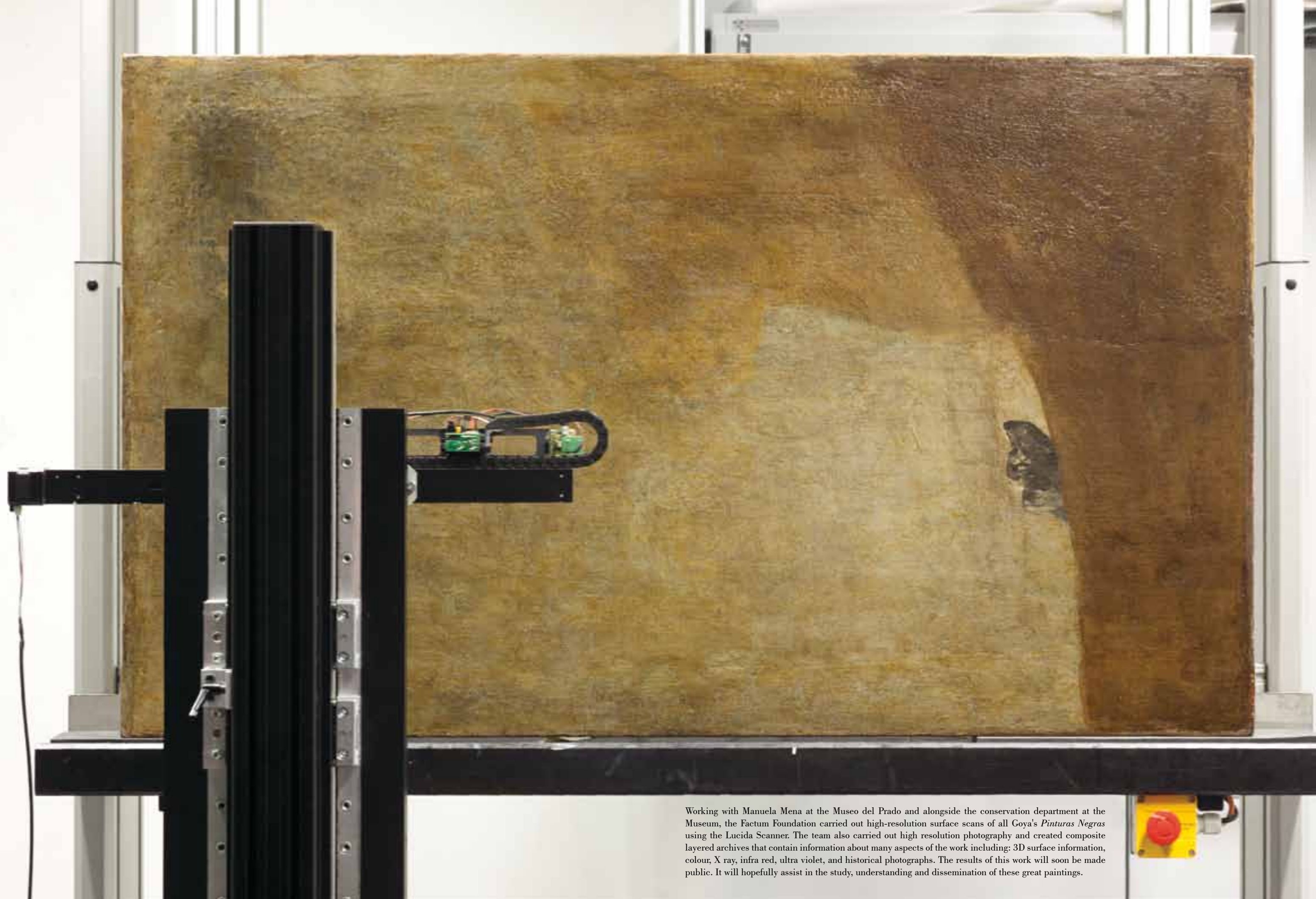

Working with Manuela Mena at the Museo del Prado and alongside the conservation department at the Museum, the Factum Foundation carried out high-resolution surface scans of all Goya's *Pinturas Negras* using the Lucida Scanner. The team also carried out high resolution photography and created composite layered archives that contain information about many aspects of the work including: 3D surface information, colour, X ray, infra red, ultra violet, and historical photographs. The results of this work will soon be made public. It will hopefully assist in the study, understanding and dissemination of these great paintings.





Giovanni Bellini, *The Assassination of Saint Peter Martyr*, probably about 1507, oil and tempera on wood. National Gallery of Art, London.



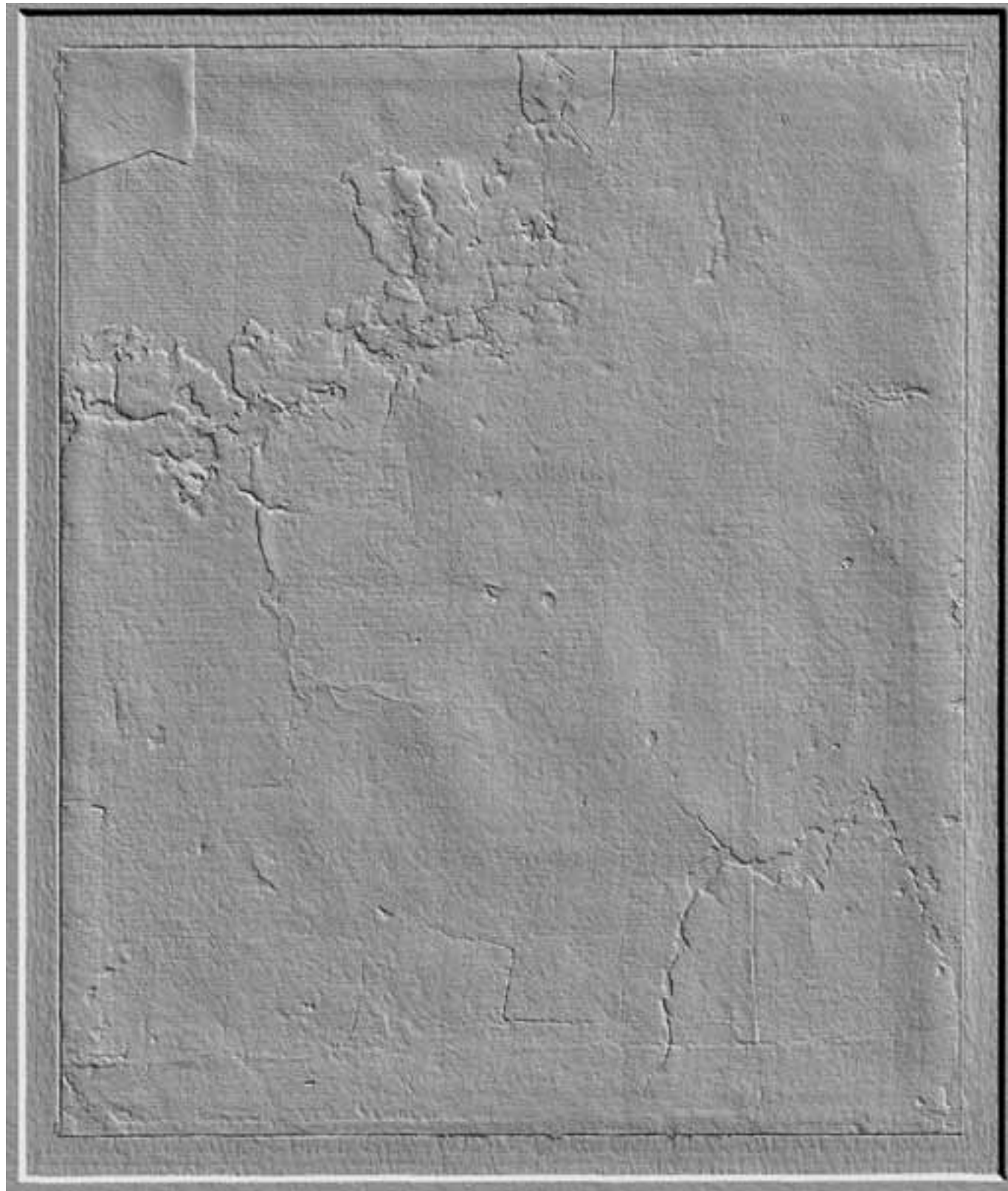

A composite image of one of the Raphael drawings at the Ashmolean Museum, Oxford.

A series of eight original drawings by Raphael, including *The Holy family with Lamb*, were recorded with the Lucida 3D Scanner in 2015 at the Ashmolean Museum, University of Oxford. This is the first time high-resolution surface data could be obtained from these important drawings. The scanning facilitated the detailed study of pouncing marks along the drawn lines. Different rendering modes were used to highlight these details, which contour the work's main figures. With this specially designed tool, researchers at the Ashmolean Museum will be able to check, modify and add their own layers of information to this data through the use of Factum Foundation's online multi-layer browser. This is an ongoing research project instigated by Mark Norman, Head of Conservation at the Ashmolean Museum.



The Replica 360 Recto/Verso Scanning Table was designed by the Factum Foundation for the Fondazione Giorgio Cini (Venice) and Digital Humanities Laboratory (DHLAB) at Ecole Polytechnique of Lausanne (EPFL). It was unveiled in Venice in February 2016.

The 360 Recto/Verso Scanning Table was designed to scan the front and back of twelve A3 photographs mounted onto card per minute at 400 DPI. The data is automatically downloaded with metadata tags and archived. The scanner consists of a revolving, motorised table with two cameras positioned above and below it. As the table rotates, two operators place the sheets onto and remove them from the four glass plates on the table. As each plate passes a sensor, the sheet is detected and the cameras are triggered.

The Replica 360 Recto/Verso Scanner will enable digitisation of the photo library in the Fondazione Giorgio Cini which contains roughly 800,000 annotated photographs of paintings from the Veneto. This is the most complete and important photographic record of the history of the art and

architecture of Venice. All the data will be collected by DHLAB at EPFL, where the images will be processed with specific algorithms to facilitate archiving while automating the flow of data and building a detailed database. Frederic Kaplan and Isabella Da Lenardi at DHLAB have developed a computer vision search engine capable of automatically organising the scanned works to facilitate the study of genealogical affinities between different works of art. This is possible thanks to the computing power of a cluster of computers at EPFL.

This simple and elegant system will be going through timed trials with two teams of operators. Factum Foundation's longer term goal is to work with the Fondazione Cini and EPFL to found and operate a Centre for Digital Technology and Preservation on the island of San Giorgio Maggiore.



The Cardinal Cisneros' sepulchre is in the Chapel of Saint Ildefonso in Alcalá de Henares, the hometown of Miguel de Cervantes. It was built in 1499 under the direction of Pedro Gumiel. The Renaissance sepulchre of Carrara marble was made by Domenico Fanchelli and Bartolomé Ordoñez between 1518 and 1521, and then surrounded by an elaborate bronze railing made by Nicholas de Vergara "el viejo" and finished by his son Nicholas de Vergara "el mozo". The railing was commissioned in 1566 and finished in 1591. In the nineteenth century, due to the sale of the Chapel, the elaborate structure was moved to the Cathedral of St Justus and St Pastor in Alcalá de Henares. In 1937 during the Spanish Civil War, the sepulchre and the railing were badly damaged by air strikes. As a result they were moved again and stored in the Museo Arqueológico Nacional in Madrid. In the C20th the sepulchre was returned to its original location in the Chapel of San Idelfonso but what is left from the bronze railing stayed in the Museo Arqueológico Nacional. Factum Foundation is working with the University of Alcalá de Henares to give courses in the application of technology to preservation. It was decided to build the course around a specific example with a complex history, The Sepulchre and bronze railings were chosen as there are photographic records before and after the bombing and a full recording of the sculpture in its current state will raise many important questions about the aesthetica and practice of preservation, conservation and restoration (both physical and virtual).
Image from Fototeca del Instituto del Patrimonio Cultural de España, MECD. Vaamonde, *La tumba del Cardenal Cisneros, después de uno de los bombardeos sufridos por esta ciudad, 1936-1939.*

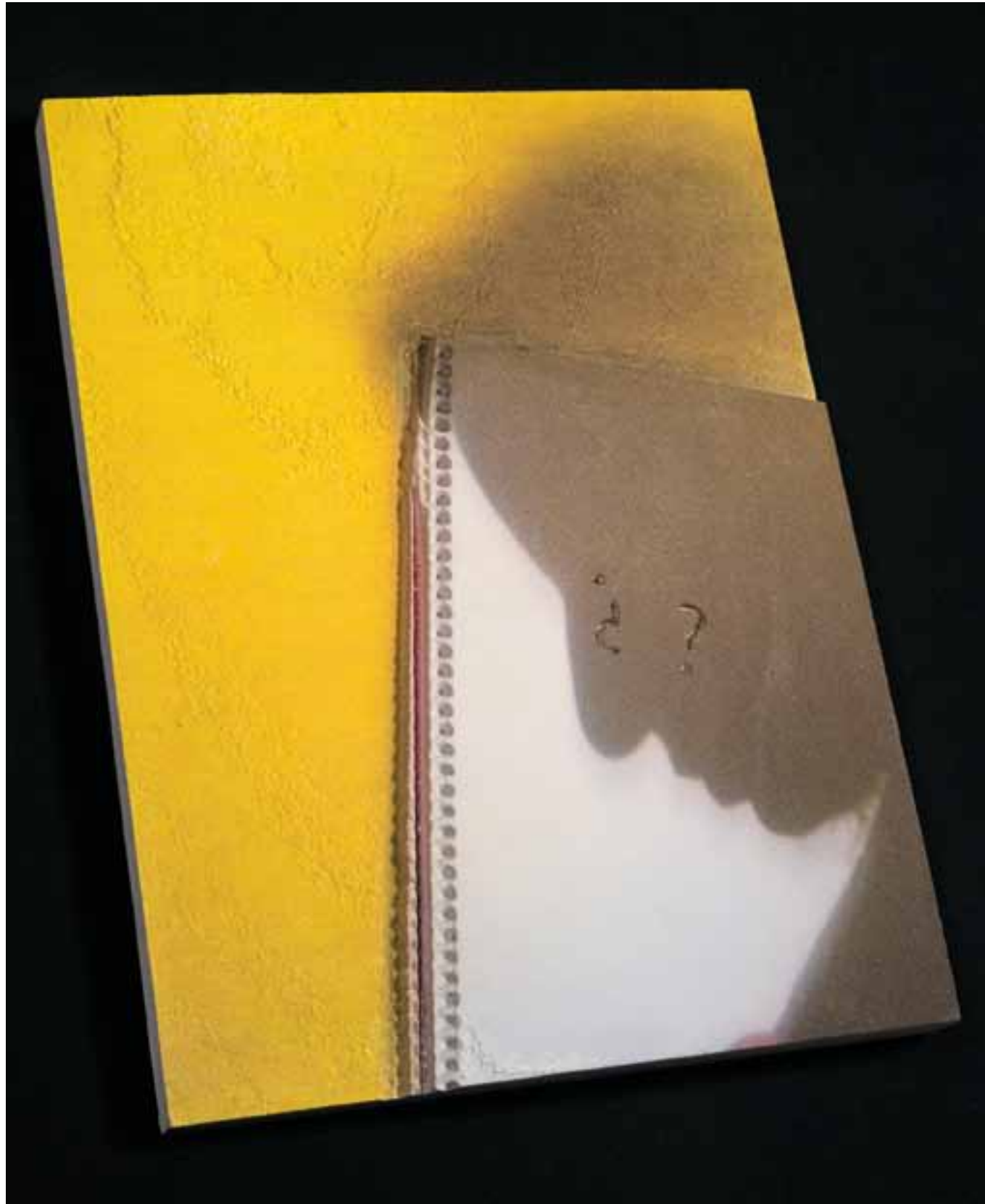

Hilda Barrera, Untitled, Mexico, 2010. Milled into a block of plaster, printed and locally varnished.

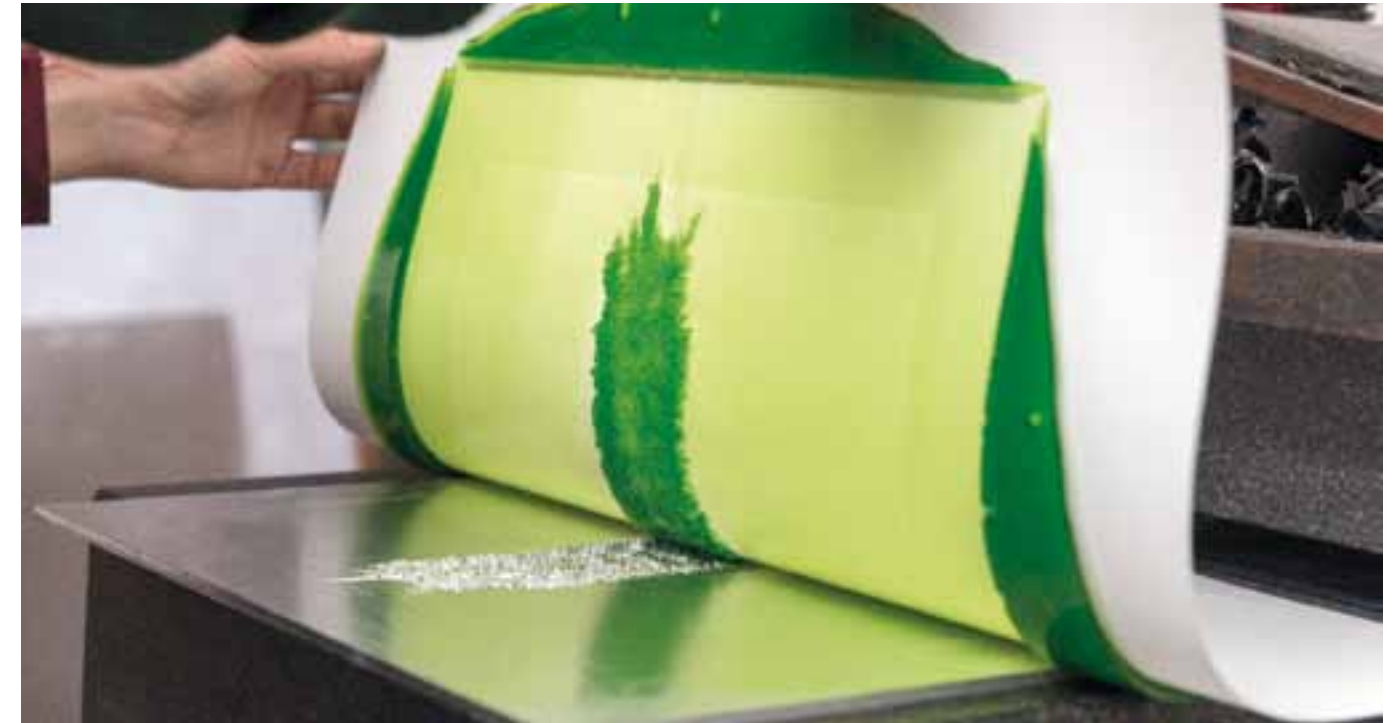

Aaron Ramos, Untitled, Mexico, 2010-15. Digitally routed 'woodburytype' print in green gelatine.

I use my senses – hearing, touch, taste and smell – when taking pictures. When I touch the camera lens I create an imaginary line from the lens to the object I am taking a picture of; I create the picture in my mind, I feel it and construct it to communicate feelings to the normal-visual world.

Aarón Ramos, *The Blind Photographer*,
Redstone Press, 2016.

In collaboration with Redstone Press and inspired by their publication *The Blind Photographer*, Factum Foundation has funded the production of an exhibition of prints and tactile images that will be exhibited at Galerie Huit between 24th July -23th September as part of The Rencontres d'Arles. The ten tactile images, made by Constanza Dessain have been designed to appeal to both the blind and the sighted.

Tactile Typography

In 1821 Charles Barbier visited Sebastian Gillé (the director of the Institut Valentine Häuy where Louis Braille was a student) to seek help to get his 'night writing' recognised. He hoped that its use as an aid to the blind would assist his attempts to persuade the army to adopt it for encoded communications. His system consisted in a series of 12 raised dots on a strip of wood that could be combined to form letters. This system was the inspiration for the development of Braille and for other forms of tactile typography.

Synaesthesia

Digital data is inherently synaesthetic – Sight can be converted to appeal to touch. Audible input can be visualised, as can smells. Taste can become sound – any sense can now be transformed into another and the potential as a communication tool cannot be overstated.

The relationship between tone and form is one of the central areas of research for the Factum Foundation. The Lucida scanner records black and white video images and converts this into a depth map. The work with photogrammetry involves the conversion of multiple images into a cloud of points in space. With recent experiments in Woodburytype printing the depth of the indent in the plate conditions the darkness of the tone – a very shallow mark will produce the lightest tone while the deepest point will produce the darkest tone and the most relief (see above). In the routed alabaster 'lithophanes' that Factum Arte have been producing for Marina Abramovic the lightest tone is created by a deep routing to produce a thin alabaster through which the light can pass while the blackest black is at the thickest point in the block obscuring more light.

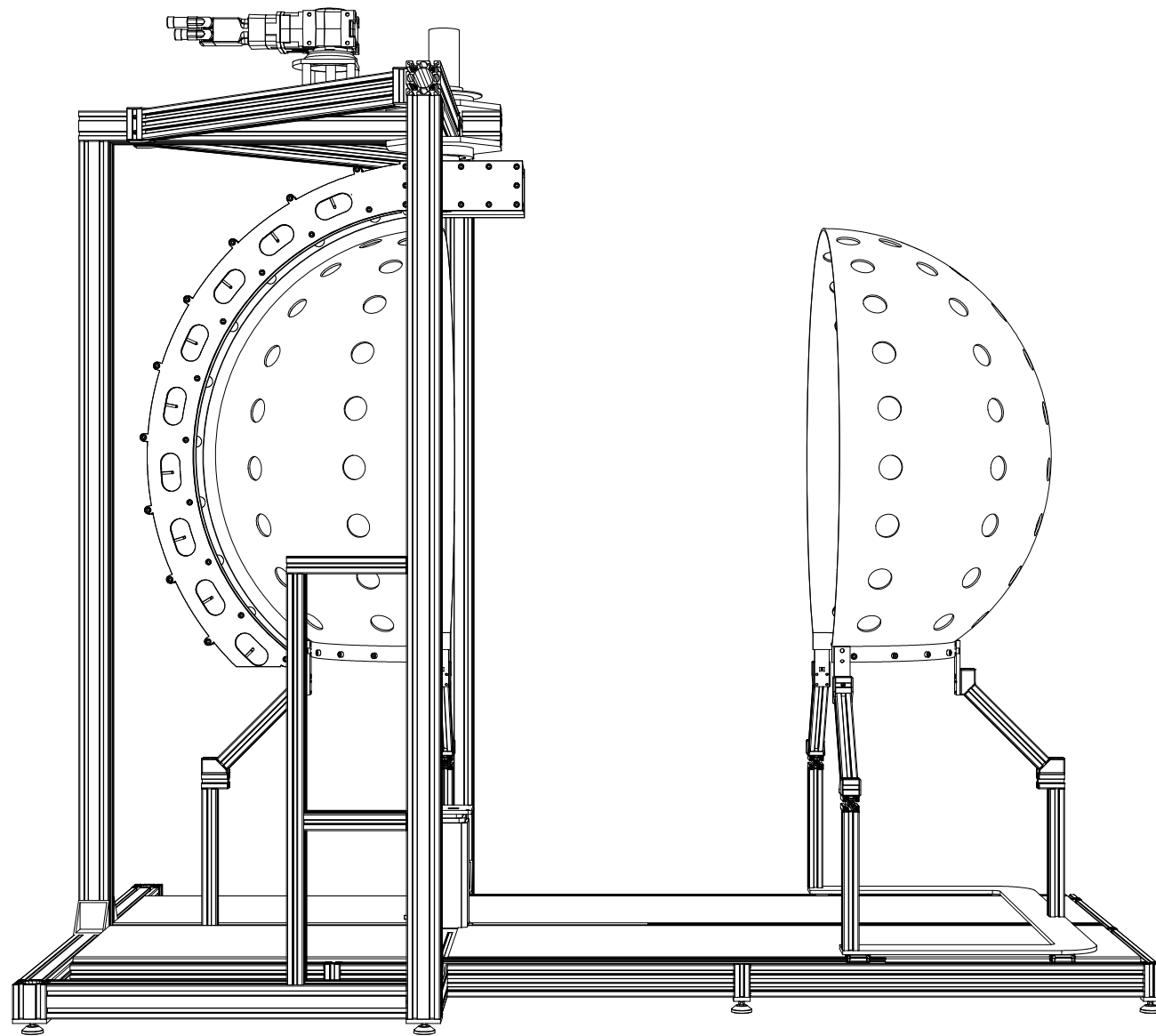

Portrait of Elisabeth Lalouschek made using the Veronica Chorographic Scanner with some retouching of her hair using ZBrush software.

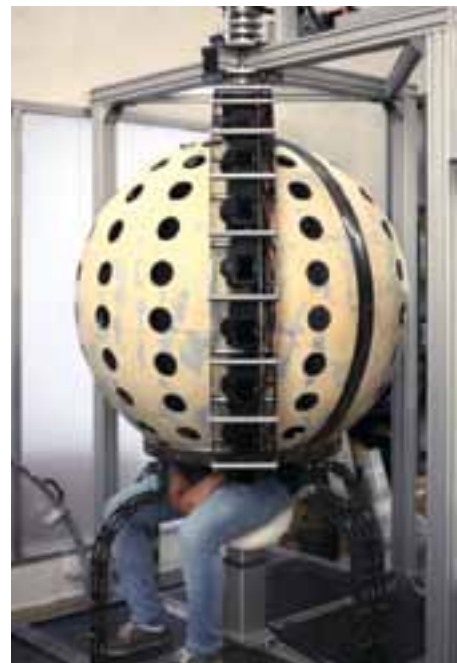

An early prototype of the Veronica Chorographic Scanner.

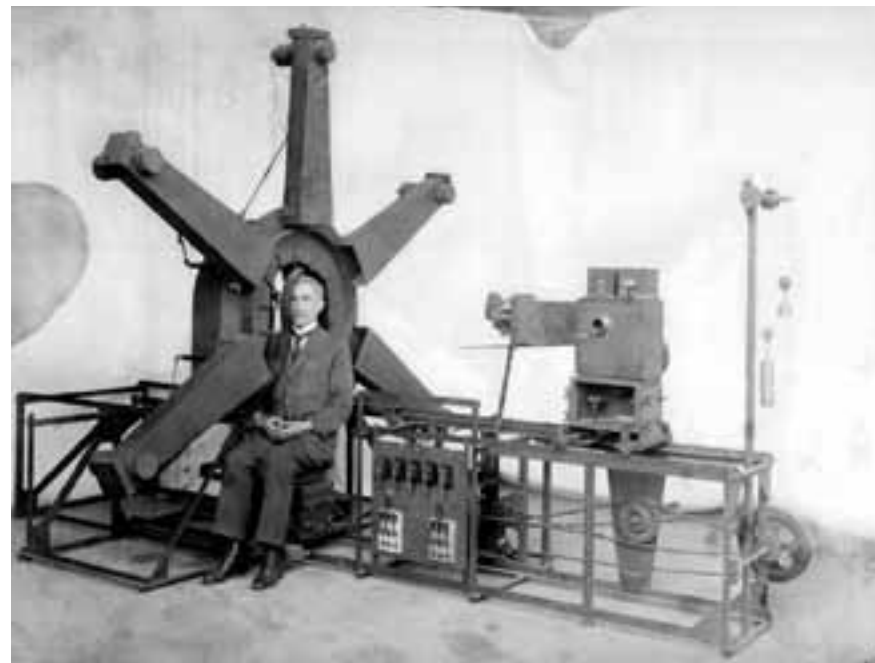

Early 3D photography system. Claudius and Xavier Givaudan. Courtesy of Musée Nicéphore Niépce, Chalon-sur-Saône.

The Veronica Chorographic Scanner is a bespoke 3D scanner designed by Manuel Franquelo Jr. and built in Factum Arte to record faces and objects within a 50 x 50 x 50 cm range. Originally conceived for the anti-aging industry, the Veronica is specifically designed to capture the fine surface detail of the human face. However, the technology is not limited to faces - any object that fits within the range of focus and can stay still for 4 seconds can be captured as well. The Veronica records its subjects through photogrammetry, extracting three-dimensional data from two-dimensional images.

Veronica is a portmanteau of the Latin word *Vera* (truth) and the Greek word *εἰκῶν* (icon or image). In line with the desire of classic sculptors, this 3D photogrammetric system is capable of producing a perfect likeness without the need for subjective and manual interventions.

The Veronica's data can be used by a whole host of output devices that print in layers, harden liquids, carve or use other methods to materialise volume from a cloud of points. The data can be materialised in an array of materials such as alabaster, marble, resin, waxes to be used to cast bronze, silver or gold, Murano and crystal glass and laser etched

blocks of glass. For more ephemeral applications, it is possible to print in chocolate, ice, salt and sugar and many other edible or transient materials.

The scanner will be the centrepiece of an exhibition at the Royal Academy in London. *Image and Form: A Photogrammetric Phenomenon* (working title) is a collaboration between the Jacob Rothschild Foundation, the Factum Foundation and the Royal Academy. It will run from 2- 10th September and will produce over 400 high-resolution scans of members of the public. The exhibition will be built around the scanner, and the data will be presented on a large screen as it is processed. A 3D printing system and a 7 axis robot will materialise the heads in real time, to produce a growing collection of busts that will add to an exhibition about the history of photography as a 3D recording tool.

After the Royal Academy the exhibition will move to Waddesdon where more people will be recorded. The aim is to continue this scanning during 2017 and part of the celebrations for the 250th anniversary of the RA.



A portrait of Stephen Rubin in gold plated bronze and alabaster made from a 3D print of data recorded with the Veronica Scanner.



A mask of Daniel Wolf in alabaster. Daniel Wolf was one of the first people to be scanned using a prototype of the Veronica Scanner. This mask was CNC milled from a block of alabaster.



Ten pages from a *Martirologio* from the confraternity of the Battuti Neri di Ferrara (1489) were recorded using composite photography and a macro lens. The problem with macro photography is depth of focus - the solution is focus stacking. Multiple images are taken with different points of focus. These are then stitched together selecting only parts of the image that are in perfect focus. The pages from this manuscript have been recorded so that they can be reproduced at 220 cm high and printed onto a surface resembling vellum – they will form part of the exhibition *Mindful Hands* at the Fondazione Giorgio Cini which will open in September 2016.

Book Scanner designed to record the miniature Offiziolo by Giovanni Pietro Birago



The book scanner is designed as a prism and a camera system with integrated lights. The prism is made of solid optical glass. The book being recorded is gently placed on top of the prism and allowed to find its natural position. No pressure is applied and the book is only open at 45 degrees during the recording. The vertical plane is clear and the angled plane is mirrored. The page being recorded is reflected downwards where it can be seen by the camera. The system has integrated lights (low temperature high-CRI LEDs) giving an even coverage over the vertical surface of the prism. A Canon 5DIII with a 100 2.8 macro lens is attached to a micro rail fitted to the frame so that the focus can be precisely adjusted. The maximum resolution is about 2200 dpi.

The book scanner was designed to record a miniature Offiziolo that was painted by Giovanni Pietro Birago and given by the duke of Milan, Ludovico il Moro to Charles VIII, King of France (1494-5). This miniature book (6 x 3,8 cm) was recorded in two days at 22000 dpi. The resulting documentation will be produced as a facsimile that can be handled and as enlarged prints that will be part of the exhibition *Mindful Hands*. The exhibition will open at the Sala de Convitto in the Fondazione Giorgio Cini in September 2016.

Both the method of recording and of making the facsimile will form part of the exhibition.

The Fondazione Giorgio Cini holds one of the most important collections of Illuminations, both bound and as 'cuttings'. The collection was purchased in 1939 from the Milanese bookseller Ulrico Hoepli who assembled it from a number of sources including the Venetian art dealer Abbé Luigi Celotti and the English artist/collector Charles Fairfax Murray. Murray worked as John Ruskin's copyist in Italy and the title of the exhibition refers to Ruskin's description of manuscripts as a mix of 'Art' and 'Curiosity' – Ruskin considered the text (the 'curiosity') irrelevant and he freely cut the illuminated images (the 'art') from manuscripts. For Ruskin these detailed and colourful images in a pristine, unrestored condition, gave an insight into the skill and taste of the artists working before Raphael. The collection contains illuminated letters, martyrs, choral works and liturgical books and Mariiegola (statutes of the schools of Venice).



A commission from the Fondazione Giorgio Cini led to the recording of a remarkable miniature manuscript, a prayer book that was painted by Giovanni Pietro Birago and given by the duke of Milan, Ludovico il Moro to Charles VIII, King of France (1494-5). This miniature book (6 x 3,8 cm) was recorded in two days at 22000 dpi using a specially designed system designed and made for the Factum Foundation. Once recorded, the digital interventions involved merging the high-resolution images of the page with information from the gutter of the book. During the recording the safe-handling of the object was the top priority and it was never opened more than 45° during the recording process.



Top: Presentation of the Lucida Lab Milano in March 2015.
 Left: Adam Lowe delivering a key-note talk at the *2 and 3D photography* conference at the Rijksmuseum in 2015.
 Public dissemination of the importance of the surface recording of paintings is at the heart of Factum Foundation's work and Adam Lowe and Carlos Bayod lecture regularly at conferences and workshops. In 2013 Adam Lowe was made a Visiting Professor at Central St Martin's, London and in 2016 he was appointed Adjunct Professor of Historic Preservation at Columbia University, New York.

Lucida Lab Milano is the Factum Foundation's studio in Milan dedicated to the promotion of digital technology applied to the preservation of works of art. Located within Open Care's Conservation and Restoration Department in Via Piranesi and directed by Guendalina Damone, the studio is equipped with a Lucida 3D Scanner, which is being used for a number of projects in Milan and throughout Italy. The two panels by Francesco del Cossa in the Pinacoteca di Brera (before and after restoration), Montorfano's *Crucifixion* fresco in the Cenacolo Vinciano, a series of panels by Bernardino Luini in the Pinacoteca Ambrosiana and a painting by Alberto Burri in Bergamo are only few of the artworks recorded since the Lucida Lab Milano was established in 2014.

In addition to the different digitising projects, dissemination is an essential part of the studio's activity. Frequent visits and seminars in the studio are being organized to share and discuss the importance of 3D scanning for Cultural Heritage. Regular training sessions are being organized with conservators, restorers and students as an introduction to the process of digitally recording a work of art, from scanning to processing the information and then finding the correct uses and applications of the data. Special attention is put to the re-materialization of the digital data and its experimental integration within the conventional practice of restoration. Factum Foundation's approach to non-contact preservation is providing a new resource within conservation practice. It is gaining increasing attention from Italian public and private institutions in the field of art preservation.



Attributed to Gaudenzio Ferrari, *Angelo annunciante*, C16th, tempera on panel, in the collection of Società di Incoraggiamento allo Studio del Disegno e di Conservazione delle opere d'arte in Valsesia, Onlus, Varallo.

In April 2016, after a thorough analysis of all the applications, the Scientific Committee (composed of Giorgio Bonsanti, Francesco Cataluccio and Serena Romano) selected the "Angelo Annunciate" attributed to Gaudenzio Ferrari belonging to the "Società di Incoraggiamento allo studio del disegno e di conservazione delle opere d'arte in Valsesia (Varallo)" as the winner of the competition.

This mid 16th century panel painting will now be the subject of a high-resolution digitisation of the surface with the Lucida 3D Scanner and composite photographic recording. An in-depth analysis using the layered archive of 3D and colour data and an observational study of the painting by the restoration team at Open Care will result in a condition report and a proposal for a restoration project.

This will be shared with the owners of the painting and with those in charge with the restoration of the panel. The competition was designed to promote a high-level of forensic study and discussion before restoration treatments are carried out. After the treatment has been done the

panel will be rescanned and re-photographed and the information will be presented as a model for conservation documentation in Italy. The recording of the surface of paintings is seldom carried out. Factum Foundation and the Rijksmuseum in Amsterdam are at the forefront of this approach to surface scanning and the creation of digital archives that bring together colour, surface, x ray, ultra violet, infra red and other multispectral information. Where possible this is cross-referenced with historical images and previous conservation records (that are normally surprisingly limited).

The Lucida Competition was announced in the Autumn of 2015 and attracted over 20 different applications from institutions all over Italy. The award is promoted and financed by Open Care - Servizi per l'Arte and Factum Foundation and has been conceived as an annual award.

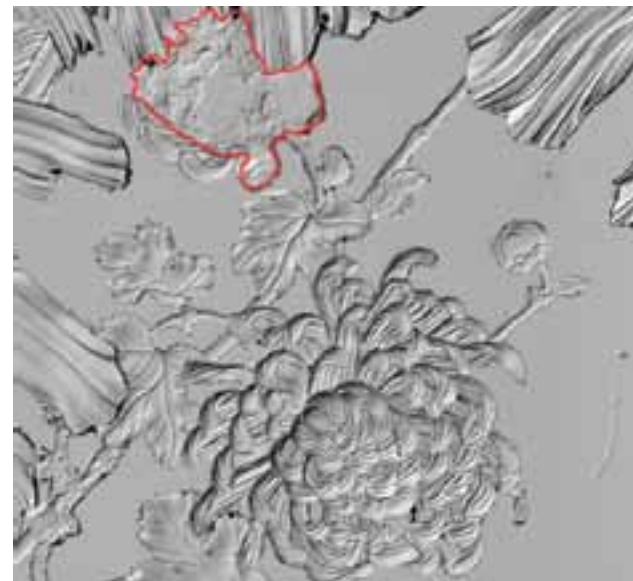

Render of the panel's relief scanned with Lucida (the area to fill is marked red).



In collaboration with Giuseppe De Gennaro, Wood Furnishing Conservator at Open Care, the Factum Foundation assisted on the restoration of a C19th Japanese cabinet. The Lucida 3D Scanner was used to record in high-resolution part of the ivory decorative inlays where there were significant parts missing. The scanned element was re-materialized using an organic modelling software and a 'replacement' part was milled. This was then physically manipulated to fit exactly into the area that needed filling.

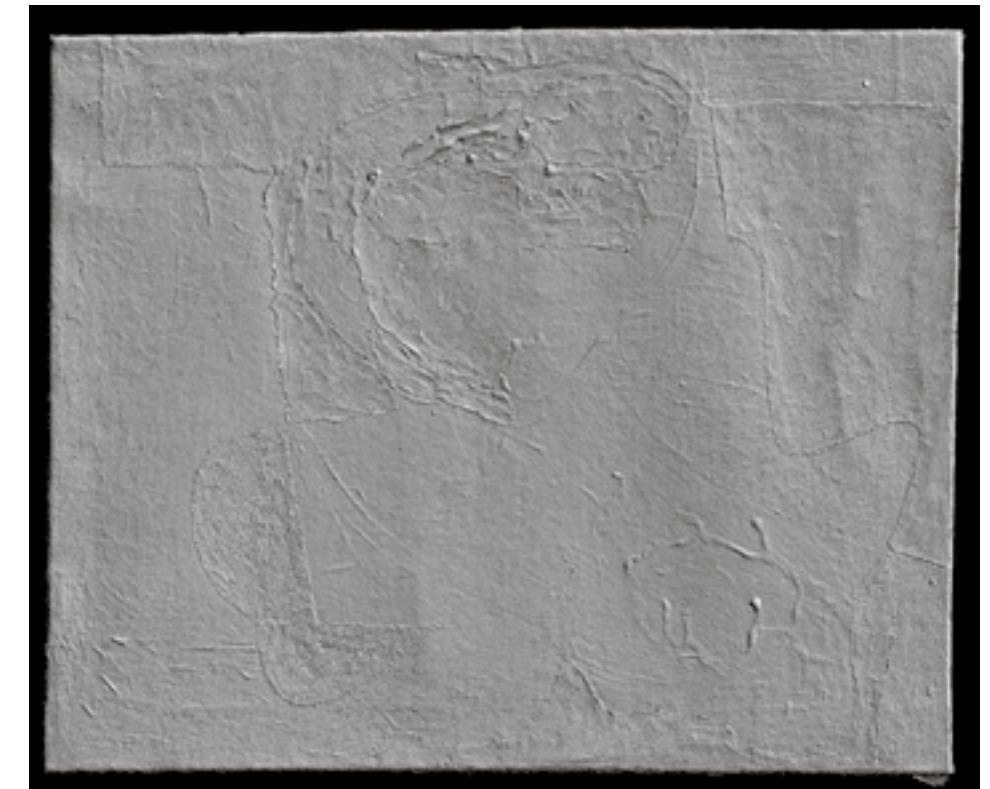

A. Burri, *Catrame*, 1950. Render of the relief recorded with the Lucida 3D Scanner.



Drips of paint carved as both positive and negative forms were cast and added to the surface.

Catrame by Alberto Burri belongs to Bergamo's Galleria d'Arte Moderna Contemporanea. It is made of oil and tar on canvas - a naturally unstable combination of materials. This work is being studied by researcher Francesca Salari (Accademia di Belle Arti Aldo Galli, Como) who is exploring some innovative conservation techniques. The painting's surface is constantly changing and some of the drips of tar that give the surface its character have gone. In order to monitor and quantify the decay the painting was scanned using the Lucida. Following the scanning the missing parts were digitally reconstructed with advanced

3D modelling software, taking the ghosts of the drop left on the surface and the volume of neighbouring drips as a reference. The intervention consisted in filling the empty area with relief and shape similar to that it once had. The digitally restored model was then CNC milled in high resolution, both as positive and negative relief, so that the drips can be cast and reintegrated onto the original surface if it is decided that this is the correct treatment by the museum's conservation department.

Conclusion

The Convention for Promoting Universally, Reproductions of Works of Art for the Benefit of Museums of all Countries was written by Henry Cole in 1867, almost one hundred and fifty years ago. It reflected the ideas and aims behind the formation of the Victoria and Albert Museum in which craftsmanship and technology merged to create a museum that was both a celebration of skill and ingenuity and an affirmation of the importance of the arts. The words of the convention are as important now as they were on the day they were written. Its intention was clear from the opening line – things become important when they are copied and shared.

Throughout the world every country possesses fine historical monuments of its own, which can easily be reproduced by casts, electrotypes, photographs, and other processes without the slightest damage to the originals.

Our time is one of 3D scanning, photogrammetry, additive and subtractive manufacturing and other methods the curious Victorians would have loved. We now know that casting and other contact copying processes can have disastrous consequences for the original objects: when the British Museum cast the polychrome works from Nimrud, the water soluble colour came off. The cast of the Portico de la Gloria by Domenico Brucciani made in 1867 removed large amounts of paint and any crumbling and exfoliating stone. The direct comparison of a plaster cast from Jacopo della Quercia's carving from the façade of the Church of San Petronio by Oronzio Lelli (1886) that was shown next to Factum's CNC milled version of the same figure (2010) was recently made possible at the V&A exhibition *A World of Fragile Parts* in the 2016 Venice Biennale of Architecture. The comparison is subtle and interesting; some features in the Lelli plaster cast are clearly finished by hand, for instance, holes in the hair have been drilled, while in the 3D milled sample there are no manual additions. In theory a direct contact cast will be more accurate than a non-contact scan. But in practice this is not the case. The nature of piece moulding results in casting lines where the moulds join. These are removed with an 'adze' (an iron age technology that is still in use), with the result that the shape of the work is accurately recorded but not its surface.

Craftsmanship is alive and well. It is now as healthy as it was when the V&A was formed. New works of art are taking form as ideas move from concept to physical presence. Ancient works are being preserved along with the evidence (embedded in the way they look) that lets us understand their biographies. The difference between making new works of art and recording/re-making the objects from the past is shrinking. Both are often dependent on the same technologies and on a new approach to the application of those technologies; an application that uses the hardware and software as part of the process of mediation and transformation. At the same time digital artisans are working with traditional craftsmen to make objects in noble materials that will last for hundreds of years. In a beautiful symmetry, traditional craftsmen are increasingly reliant upon emerging technologies. The relationship between the past and the present is merging, in the things we care about and the way we care for them. The history of the V&A is concurrent with photography, with the printing of tone (and later colour) from images recorded as negatives. You used to *take* a photograph – now you can *make* a photograph; we are in an age of photographic capture and printing in three dimensions... but we were in the same place in the 1860s when Henry Cole was championing the importance of copies. Photosculptures first appeared in 1858.



Three copies of Pauline Borghese by Antonio Canova on display in *A World of Fragile Parts* at the Venice Biennale of Architecture, 2016.
A 3D print of Paulina Borghese, the same figure in wax and Paulina Borghese cast in Glass by the master craftsman Juman for Giberto Arrivabene.

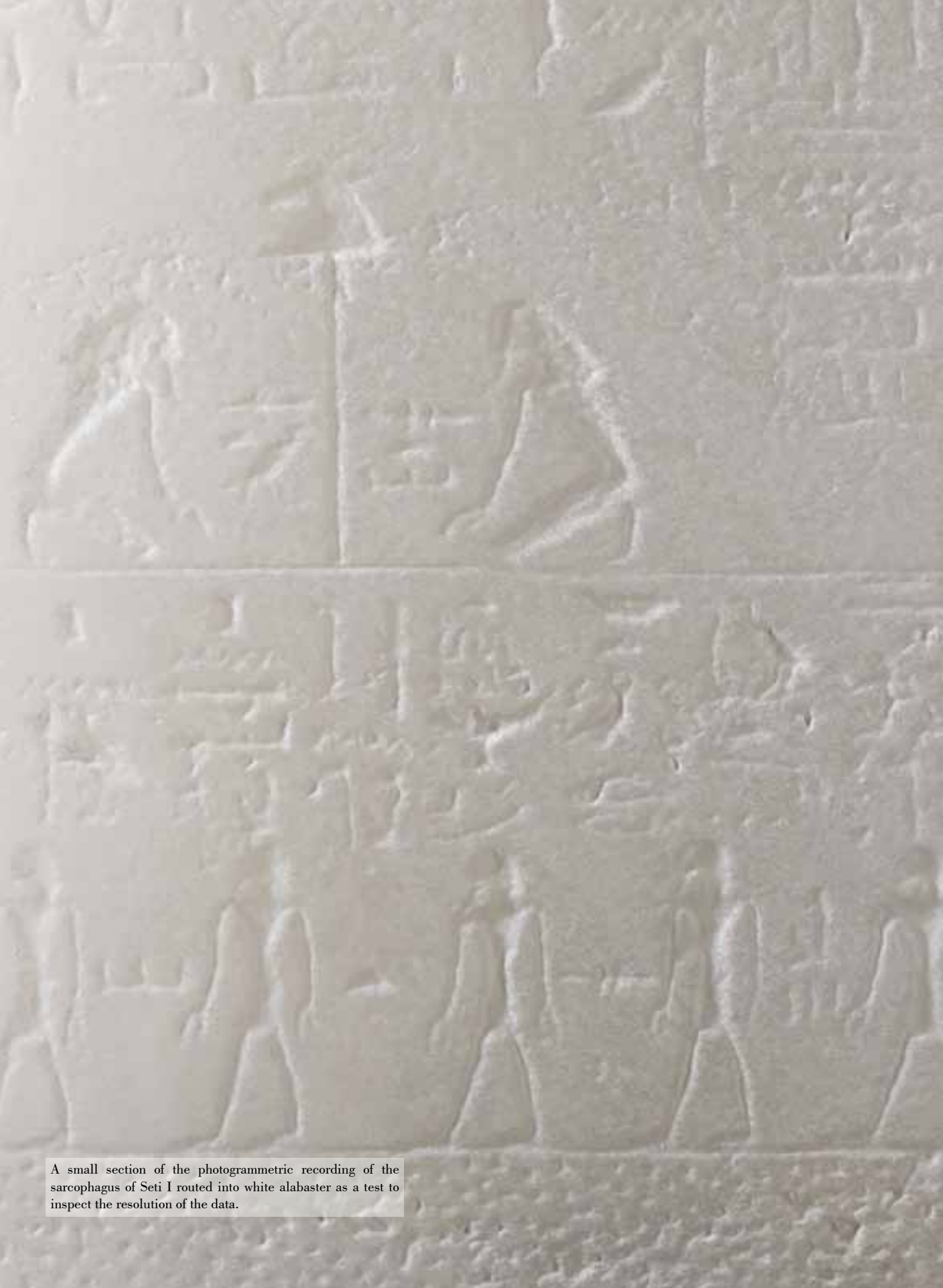

A small section of the photogrammetric recording of the sarcophagus of Seti I routed into white alabaster as a test to inspect the resolution of the data.

Unseen by the sitter, twenty-four pictures of him had been taken by twenty-four miniature cameras, cleverly hidden inside the consoles. Each camera had a shutter, and these were synchronized by a system of cords controlled by an operator. The photographs which resulted were only a means to an end, and themselves possessed no artistic quality. As Boyer pointed out, all the paraphernalia and clutter of the studio was recorded - headrests and all. But the set of negatives contained sufficient information to enable Francois Willème to make a statue with a minimum of skill of hand and effort.

La Photosculpture. Su Desarrollo en la España de Isabel II (1860 -1868)
by Leticia Azcue Brea and Mario Fernández Albarés.

This description of Francois Willème's setup to make photosculptures is conceptually similar to Manuel Franquelo's Veronica Chorographic Scanner which was funded by Factum Foundation. The Veronica Scanner can record faces with forensic accuracy. While it was originally conceived for medical and anti-ageing applications that demand objectively accurate recordings, this 3D scanner significantly found its first application making portrait busts and recording museum objects. At the same time, anti-ageing treatments that use hyaluronic acid fillers literally turn the aesthetic doctor into a sculptor working on a living face - some practitioners have emerged with the skills of a great sculptor while others work 'with a minimum of skill of hand and effort'. Just like restorers coaxing nuances of meaning out of an aged and damaged canvas, today's cosmetic sculptors revive and re-fill ageing human flesh. The treatments that we are working on ourselves change our ideas about originality. There remains a notion of things being fixed when they are constantly changing. We know that we change, and this is as true of art as of humans. The speed of the change is important and is one reason why we can react so strongly to restorations and rapid changes in the way things look. The relationship between originality and authenticity has never been less clear... or more intellectually challenging.

We need a new type of sensitive and informed connoisseurship to nurture the emerging awareness of this dynamic nature of originality and the complexity of authenticity. This knowledge has the potential to span cultural and religious differences, allowing us to understand how other people think and apply their values however different they might be from our own. This concept lies at the core of 'the preservation of fire': this is about keeping complex subjects alive rather than revering the shell they used to inhabit.

In his book *L'Hiver de la Culture*, Jean Clair wrote about the relic and the replica. He wrote about the work of Factum Arte and their copy of Veronese's *Wedding at Cana* made for the Fondazione Giorgio Cini. When Pasquale Gagliardi commissioned a facsimile, his aim was to bring Andrea Palladio's refectory on the Venetian island of San Giorgio Maggiore back to life. A replica transformed a relic into a meaningful dialogue between architecture and painting.

The works contained in this book reveal many ways in which the embers can be resurrected and grown into a raging fire. From the re-modelled 'burnt' Christ of Justo Gallego to the facsimile of C12th Cluny Christ for Rachid Koraïchi the phoenix is rising and the gap between the past and present is closing in a way that is shaping the future.

The answer, in recent years, is “digital artisans,” whose work with bespoke technologies to document and reproduce endangered objects approaches wizardry. Factum Arte, a Madrid-based atelier, is at the forefront of this new discipline combining science and art. Its sophisticated replica of Tutankhamun’s burial chamber, recently installed underground in Luxor’s Valley of the Kings, places Egypt at the heart of a revolutionary shift in heritage conservation.

Maria Golia, Middle East Institute,
“The Science of Preserving Egypt’s Cultural Heritage”, June 23 2014



FACTVM
FOVNDATION
FOR DIGITAL TECHNOLOGY
IN CONSERVATION

In order to preserve fire the Factum Foundation needs financial and political support. We have grown from nowhere, generating the funding for each project, in different ways. We are in a position where demand is outstripping supply.

There are times when one person really can make a difference. Aby Warburg did in the years before the Second World War and the holocaust. John Paul Getty did in the years after the war when it was possible to collect great things. Whose name will be associated with the revolution that is taking place as new technologies merge with traditional skills?

The art market is driven by money but that is not its *raison d'être*. The value of a work of art lies in the fact that it can change your point of view. It's a bit like being in love, you can see and feel the world from someone else's perspective.

How to Contribute to the Foundation

The Factum Foundation works worldwide to ensure that future generations may inherit the past in a condition where it can be studied in depth and be emotionally engaged with.

Many projects have been completed over the past few years, Some are described and illustrated on these pages. Others are shown on the Factum Foundation and Factum Arte websites. Some are fully funded while others are in urgent need of financial support. If you are interested in supporting, donating to, or sponsoring a project please get in touch. Your contribution will help us continue our work in re-creation, conservation and preservation on a global scale.

American Friends of the Factum Foundation

The American Friends of the Factum Foundation (AFFF) has been established as a Delaware not-for-profit company whose object is to channel funding from US donors to the Foundation in an efficient way for the US tax payer. AFFF has filed with the IRS and is awaiting approval for 501(c)3 status. The original incorporation of the AFFF was in October 2015 to which the tax status may be backdated. The creation of AFFF recognizes the potential interest we are seeing from friends of the Foundation in the United States and will, we hope, make it easier for them to support our work through a local entity. All funds received will be used by the Foundation in its heritage work around the world.



Moussa and Abdu on the roof of Stoppelaere House. They are the constant presence in Luxor who ensure that the aims of the Theban Necropolis Preservation Initiative are realised. Local knowledge is everything.

The text in this book was written by Adam Lowe and Otto Lowe. Additional help was given by Charlotte Skene Catling, Eva Rosenthal, Ferdinand Saumarez Smith, Carlos Bayod, Blanca Nieto and Jessica Corneille.

Photographic references:

© Factum Arte; Photography by Alicia Guirao, Oak Taylor-Smith, Jose Pereira, Adam Lowe, Gabriel Scarpa, Ferdinand Saumarez Smith, Eva Rosenthal, Grégoire Dupond, Sebastián Beyró, Carlos Bayod, Alexander Peck, José Manuel Pellón, Guendalina Damone.
© [didwide]/123RF.COM
© Tarek Waly Studio
© Ksenia Sidorova
© David Coulson (TARA)
© Basilica di San Petronio
© Victoria & Albert Museum
© Hereford Mappa Mundi Trust
© Luke Tchalenko
© The Griffith Institute, Oxford
© Ministerio de Educación, Cultura y Deporte. Instituto del Patrimonio Cultural de España, Fototeca del Patrimonio Histórico
© Fondazione Giorgio Cini
© Bodleian Libraries
© Yale University Library
© Museo del Prado
© The National Gallery
© Ashmolean Museum, University of Oxford

Design by Blanca Nieto.
Printed by Julio Soto Impresor in Madrid.
Legal Deposit M-21660-2016

To contact the Factum Foundation:

info@factumfoundation.org
www.factumfoundation.org

in Madrid

c/ Albarracín, 28
28037 Madrid
tel. +34 915 500 978

in London

44 Lexington Street
London W1F 0LP
tel. +44 2074398287

LucidaLab Milano

Via Piranesi, 10
20137 Milano
tel. +39 02 36736436

